

Geant4 Applications for NASA Space Missions



Makoto Asai
(SLAC/SCCS)



Geant4 Applications for NASA Space Missions

- Geant4 is nowadays widely adopted as the simulation engine for NASA space missions.
- We will try to overview three major application areas of Geant4.
 - Apparatus simulation
 - Pre-launch design, post-launch analysis
 - Planetary scale simulation
 - Radiation spectra
 - Micro-dosimetry simulation
 - Single event effects



Apparatus simulation



The GLAST Mission



GLAST measures the direction, energy and arrival time of celestial gamma rays

-LAT measures gamma-rays in the energy range ~ 20 MeV - >300 GeV

- There is no instrument now covering this range!!

- GBM provides correlative observations of transient events in the energy range ~ 20 keV – 20 MeV

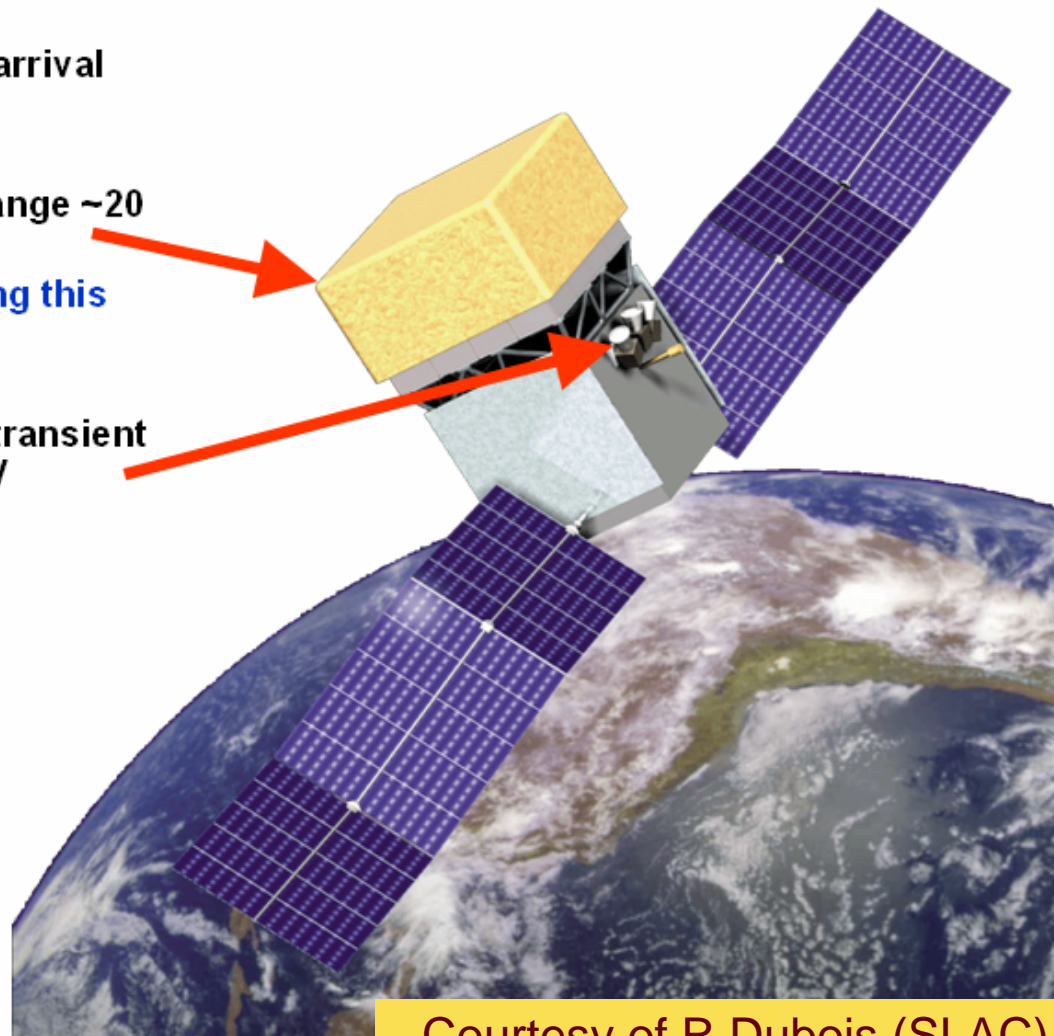

Launch: February 2007
Florida

Orbit: 550 km,
28.5° inclination

Lifetime: 5 years
(minimum)



GLAST Large Area Telescope (LAT)

Si Tracker Tower

pitch = 228 μm
 5.52 10^4 channels
 12 layers \times 3% X_0
 + 4 layers \times 18% X_0
 + 2 layers

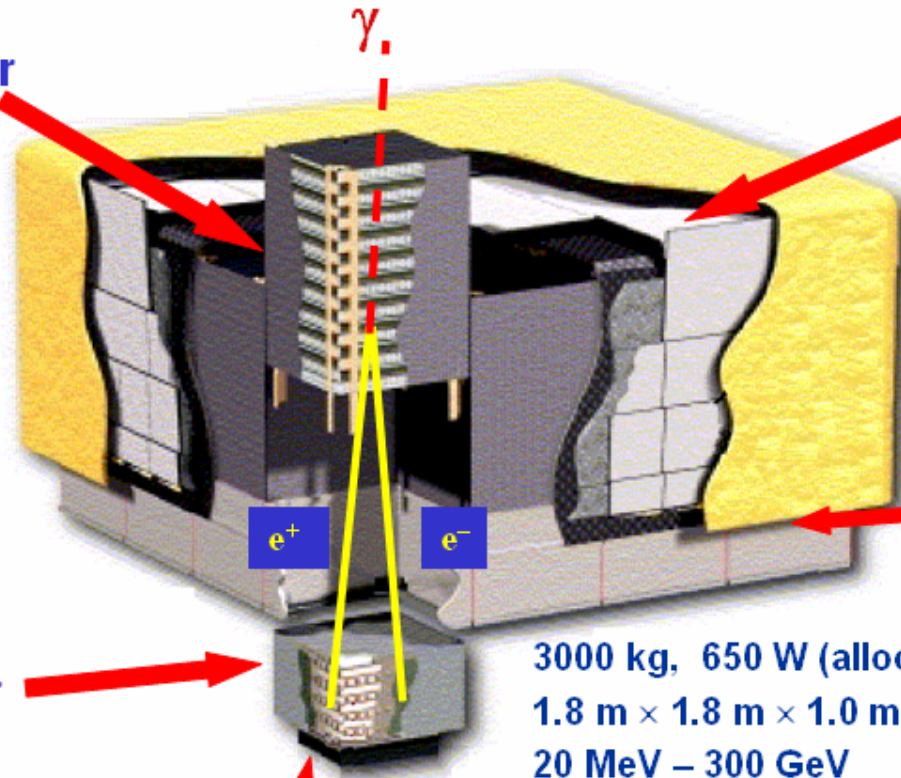

ACD

Segmented
 scintillator tiles
 0.9997 efficiency
 \Rightarrow minimize self-veto

Grid (& Thermal Radiators)

3000 kg, 650 W (allocation)
 1.8 m \times 1.8 m \times 1.0 m
 20 MeV – 300 GeV

CsI Calorimeter

Hodoscopic array
 8.4 X_0 8 \times 12 bars
 2.0 \times 2.7 \times 33.6 cm
 \Rightarrow cosmic-ray rejection
 \Rightarrow shower leakage correction



Data 
 acquisition

16 identical towers
30 Hz average downlink

C Simulation

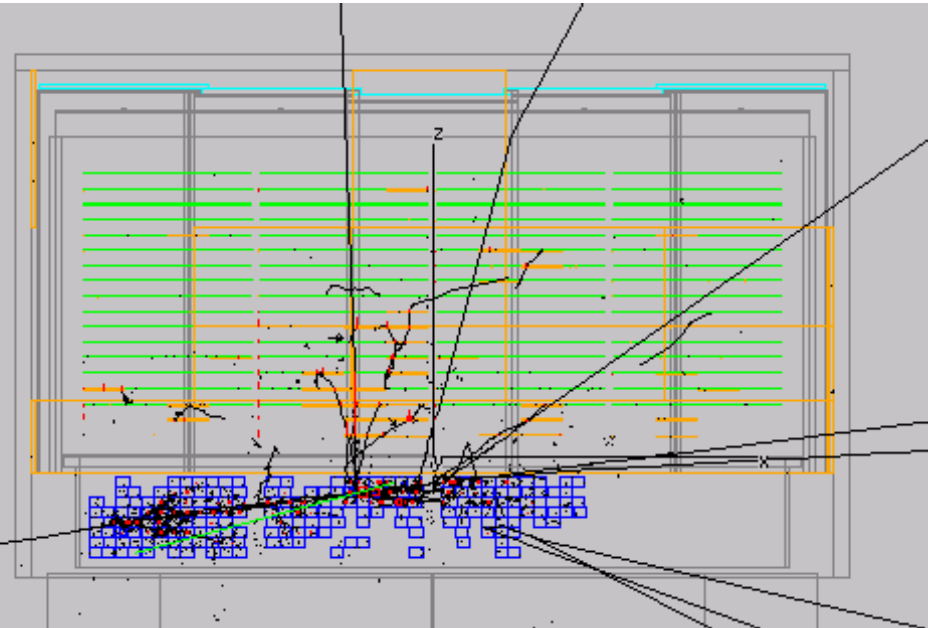
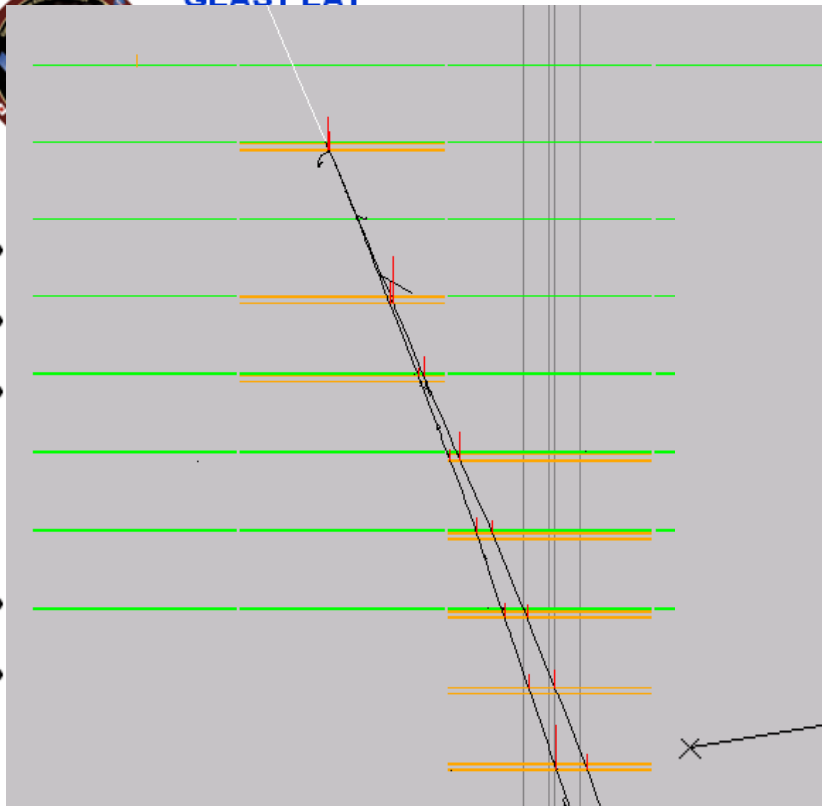

- Source generation

- Hit

- Dig

- Re

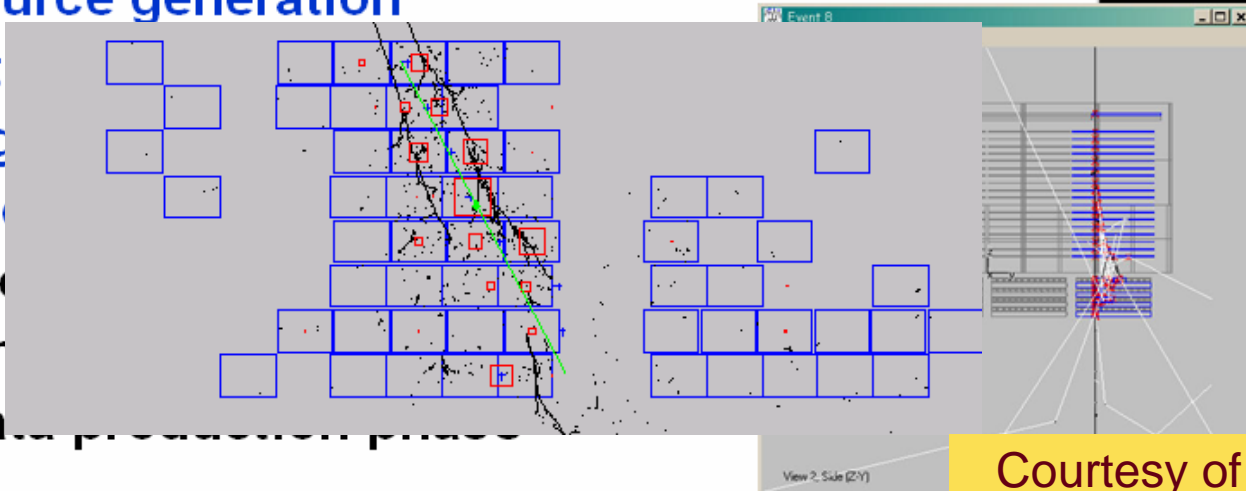

• G4 ad

• Contin

• MC da



GEANT4 simulation of the Cassini-Huygens Low Energy Magnetospheric Measurement System (LEMMS)

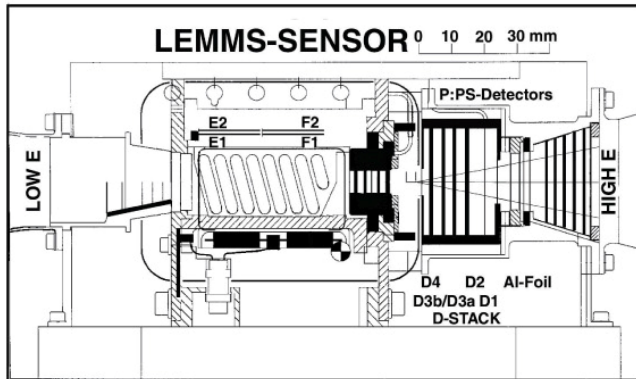

LEMMS opaque side view High Energy side

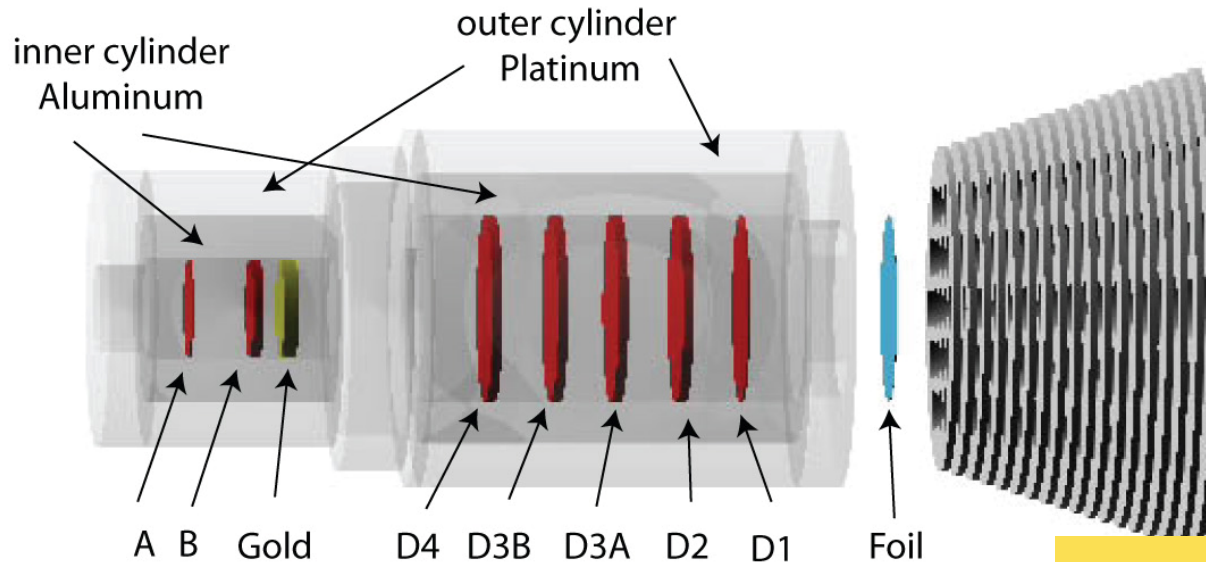
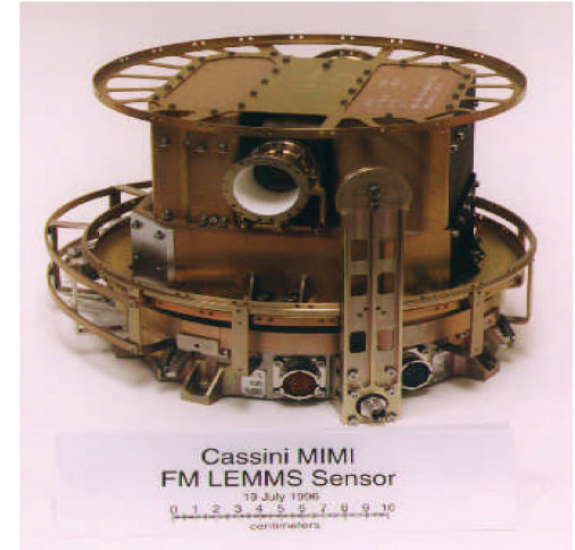

collimator (front end view)

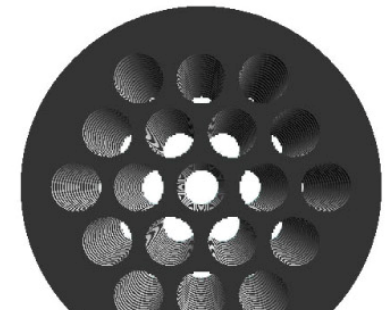



GEANT4 simulation of the Cassini-Huygens Low Energy Magnetospheric Measurement System (LEMMS)

Selected simulation views

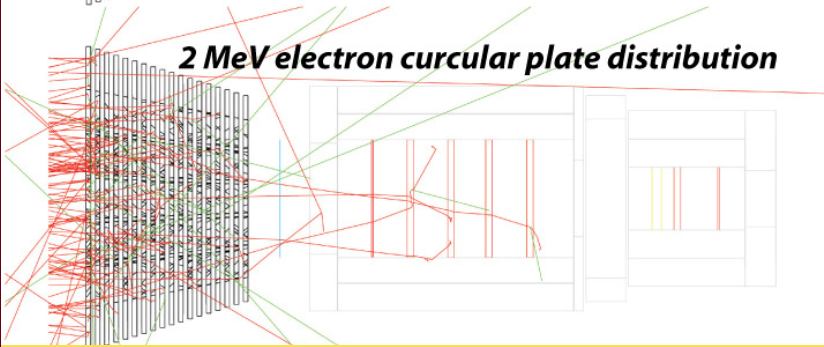
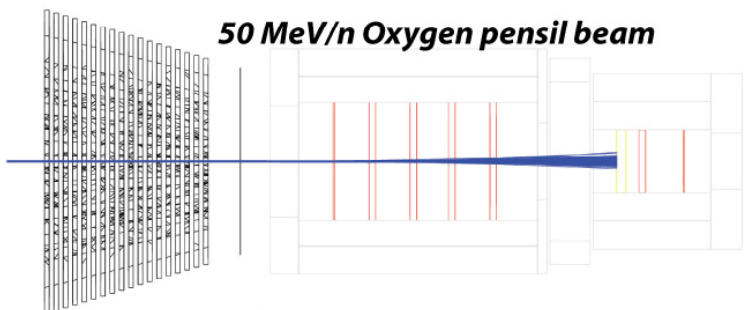
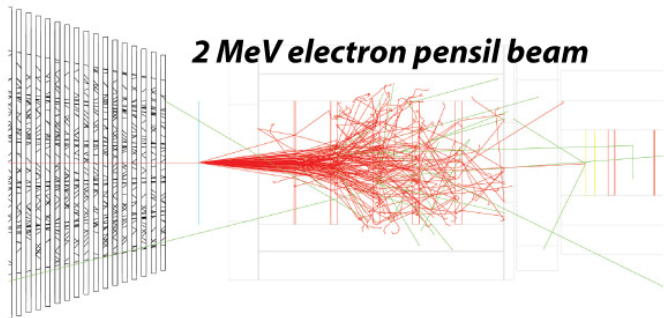

Comparison to calibration data

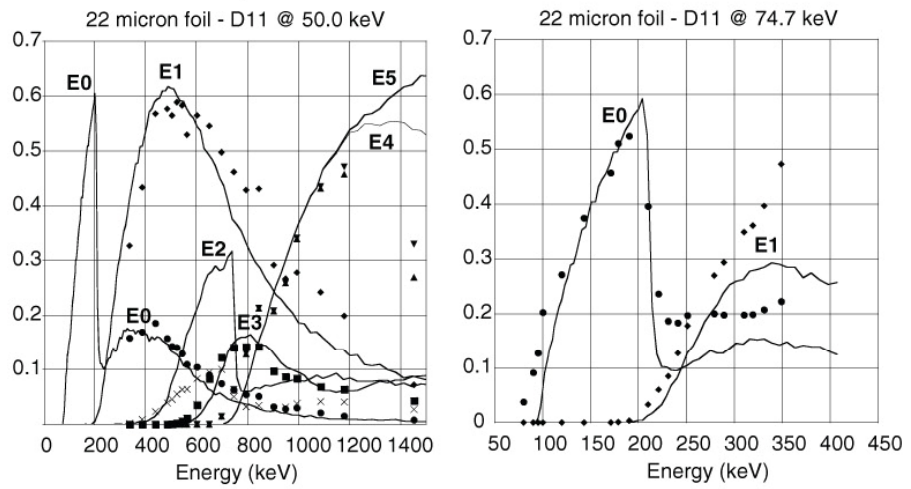

Channel efficiency and passband determination

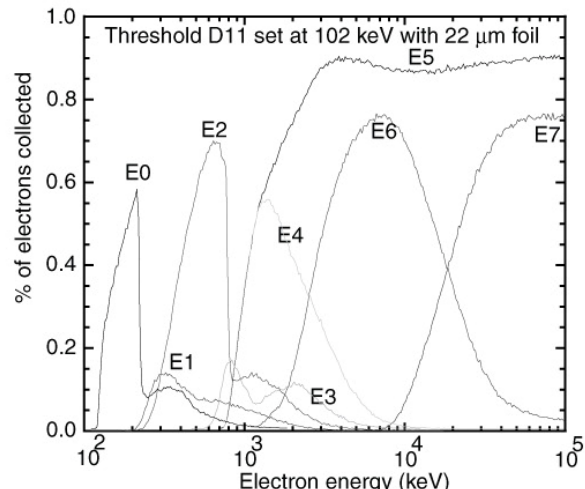

reference
Monte Carlo simulations
of CASSINI/LEMMS,
D. K. Haggerty and S. Livi
Adv. Space Res.,
33, 2303-2308, 2004

GEANT4 simulations of Solar Energetic Electron Scattering in the ACE/EPAM Solid State Detector System



Single detector simulations

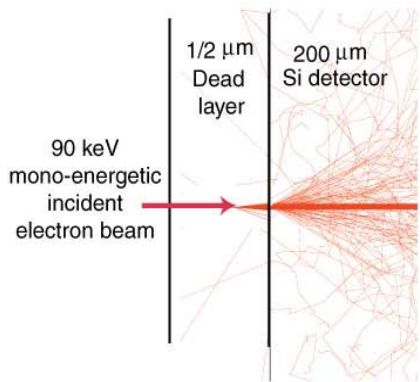

Double detector simulations Main detector and anti

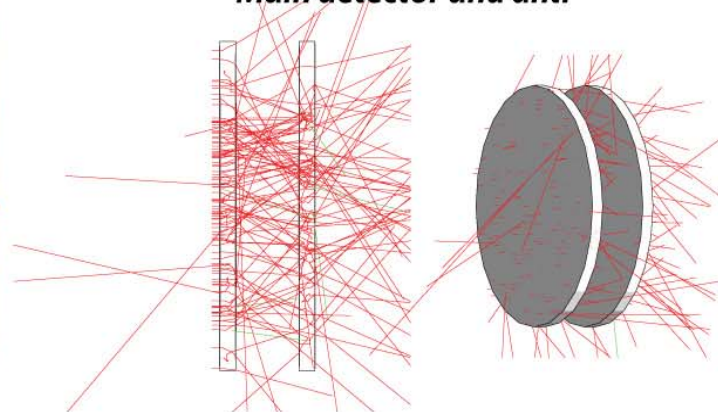
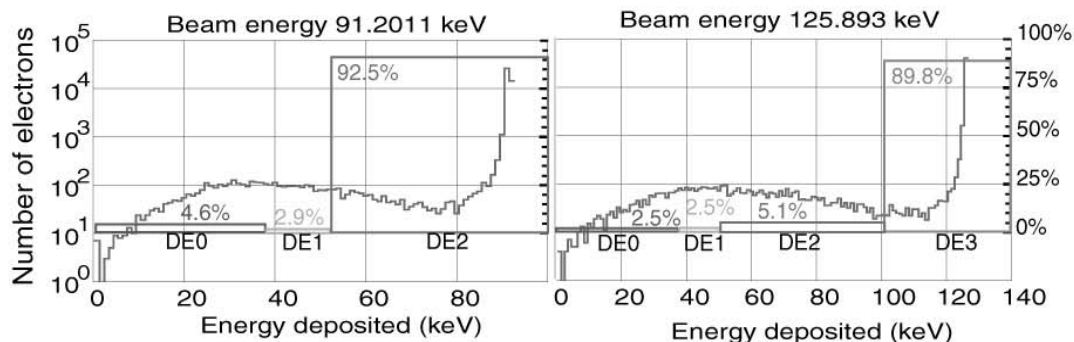

Table 1. EPAM Energy Channels

Channel	Low	High	Unit
DE0*		<38	keV
DE1	38	53	keV
DE2	53	103	keV
DE3	103	175	keV
DE4	175	315	keV
DE5*	>315		keV

* Pseudo channels

The left panel shows the simple geometry of a single detector, the middle figures show the double detector simulation. The right table shows the EPAM energy channels.



Simulation of energy deposited in the SSD due to a ~91 keV (left) and a ~126 keV (right) electron beam. A percentage of the incident electrons will trigger channels lower than the incident energy because some electrons scatter out of the SSD.

Courtesy of
K.Haggerty (JHUAPL)

GEANT4 simulations of The Messenger Energetic Particle Spectrometer (EPS)



Schematic of MESSENGER EPS

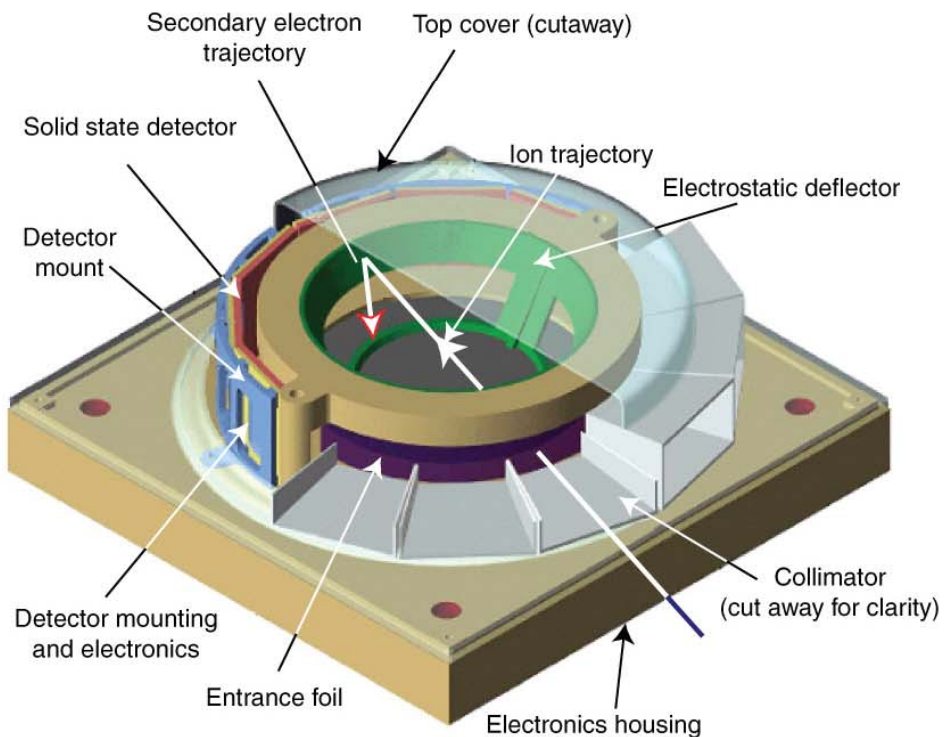

Picture of MESSENGER EPS

collimator

calibration source

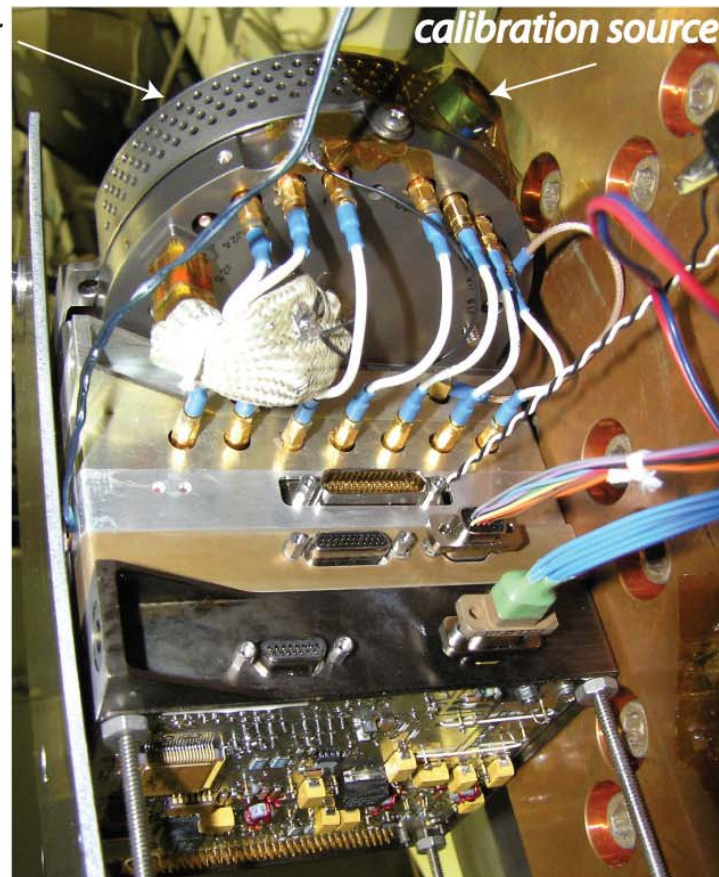

Courtesy of K.Haggerty (JHUAPL)

GEANT4 simulations of The Messenger Energetic Particle Spectrometer (EPS)



The EPS collimator

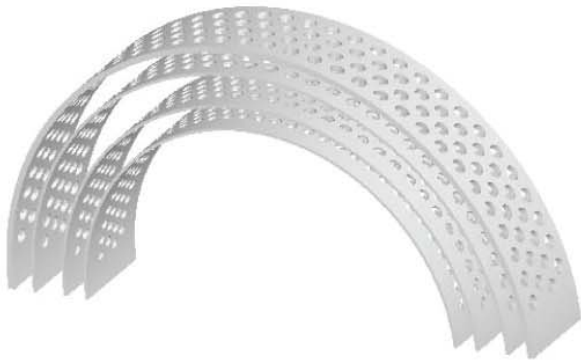

The EPS MCP high voltage cup

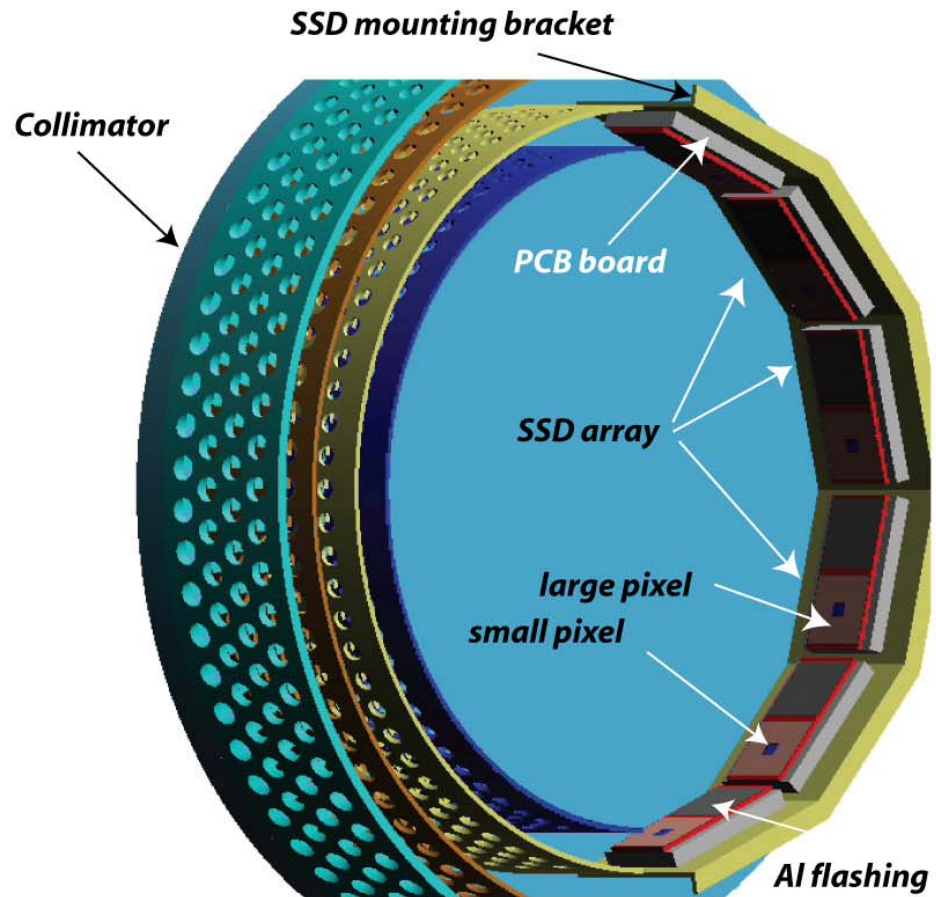
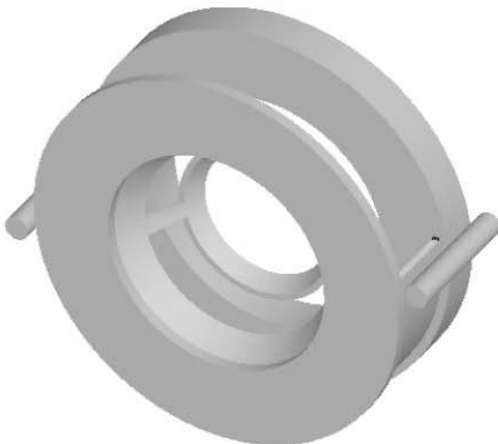

Courtesy of K.Haggerty (JHUAPL)

GEANT4 simulations of The Messenger Energetic Particle Spectrometer (EPS)



View looking into the Collimator

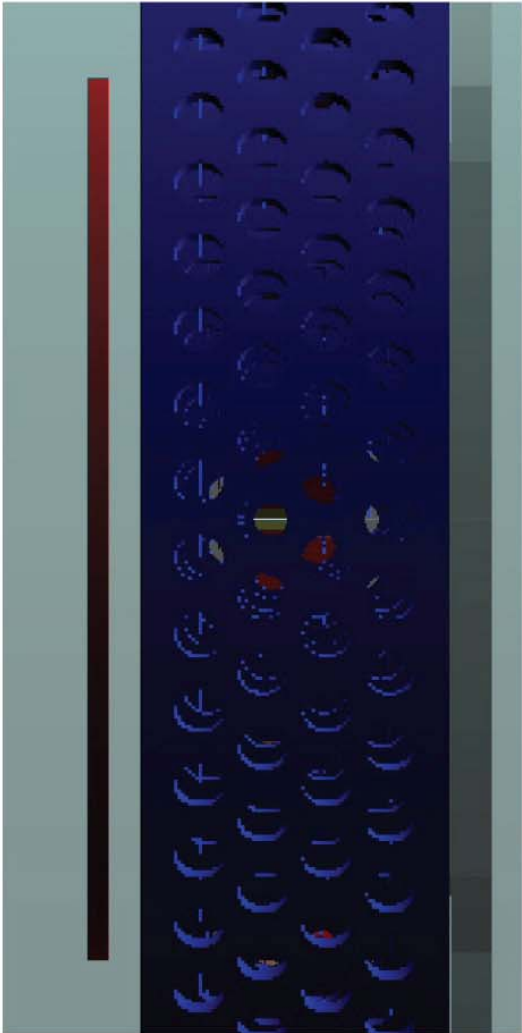

Bottom view of EPS simulation geometry

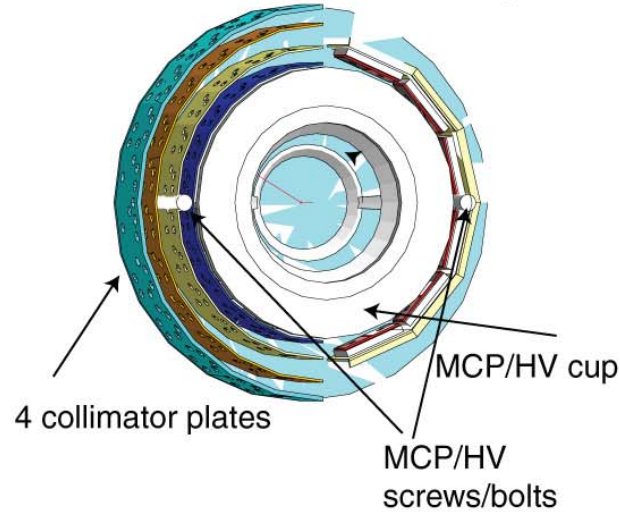

Wireframe view with some shielding

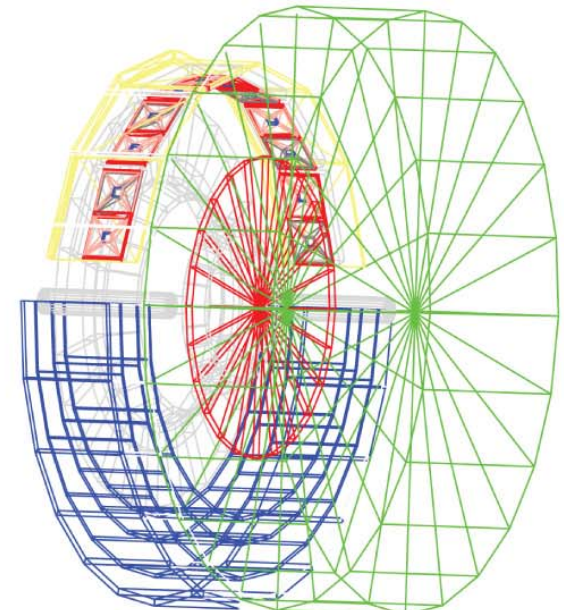
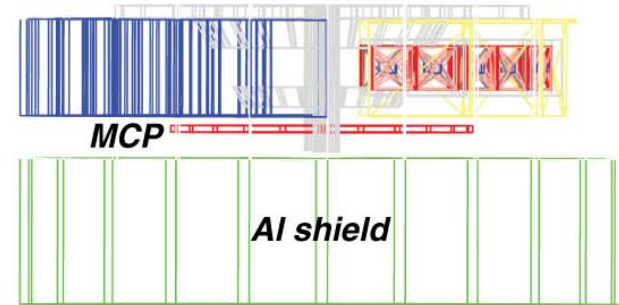

GEANT4 simulations of The Messenger Energetic Particle Spectrometer (EPS)



Simulate an isotropic environment by placing the EPS inside of a spherical shell. This simulation was using $1e+7$ 200 keV electrons

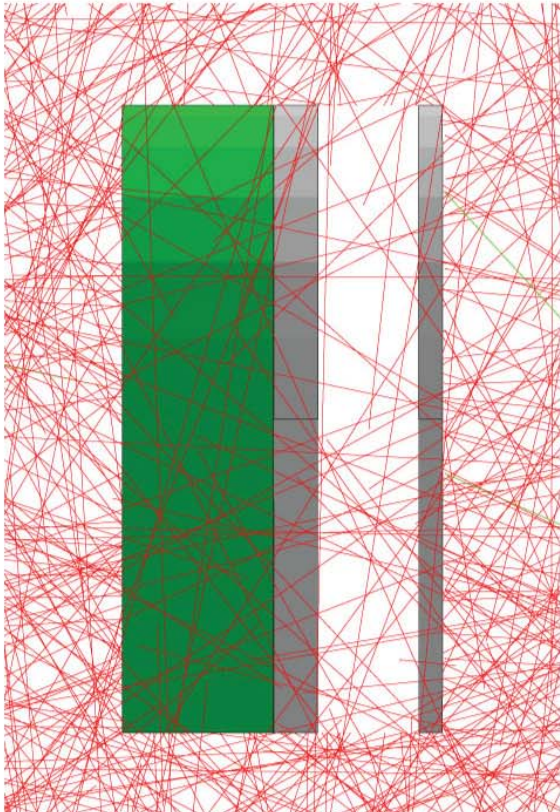

Gamma ray spectra at the MCP from energetic electrons

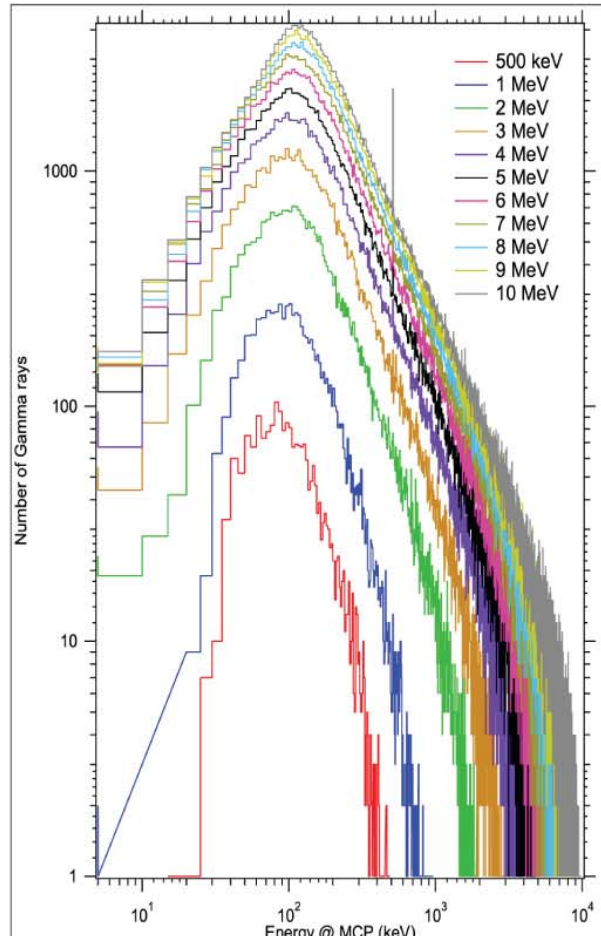

Simulations to do for Messenger EPS

Simulate the background rates due to solar energetic particle events (SEPs)

Determine the EPS geometrical factor and compare to lab tests

Examine the channel passbands

Examine the SSD rates due to solar X-rays

Examine the efficiency of the foil flashing to differentiate electrons from low energy ions

And a lot more...

Courtesy of
K.Haggerty (JHUAPL)

GEANT4 instrument development
Combined Ion and Neutron Spectrometer for Space Applications (CINS)

Applied Physics Laboratory

Conceptual design of Ion Spectrometer **Conceptual design of Neutron Spectrometer**

Charged particle telescope:
silicon + plastic scintillators + BGO scintillator

BGO 3 cm thick
Si detectors 5mm thick

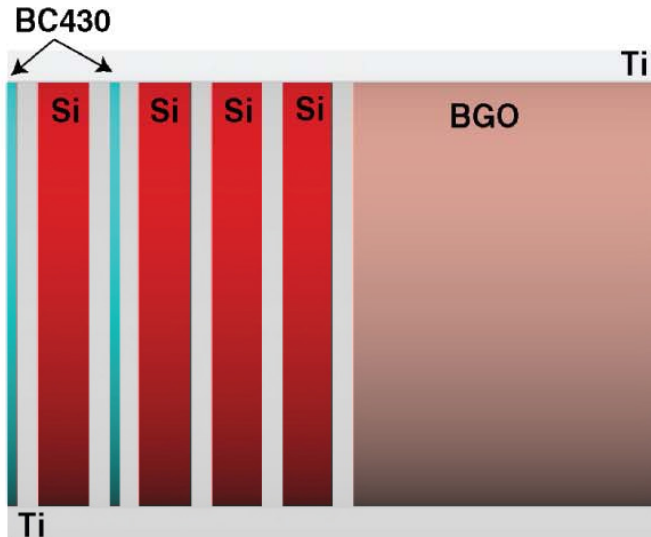

Three components:
 3He tube for low energy (thermal to 1 MeV)
 Boron-loaded plastic scintillator (Eljen) for medium energy (1-15 MeV)
 Thick Si(Li) detector with anti-coincidence shield for high energy (12-600 MeV)
 Unfolding to get incident neutron energy spectrum from deposited energy spectrum is maximum likelihood method.

GEANT4 model of High energy neutron detector

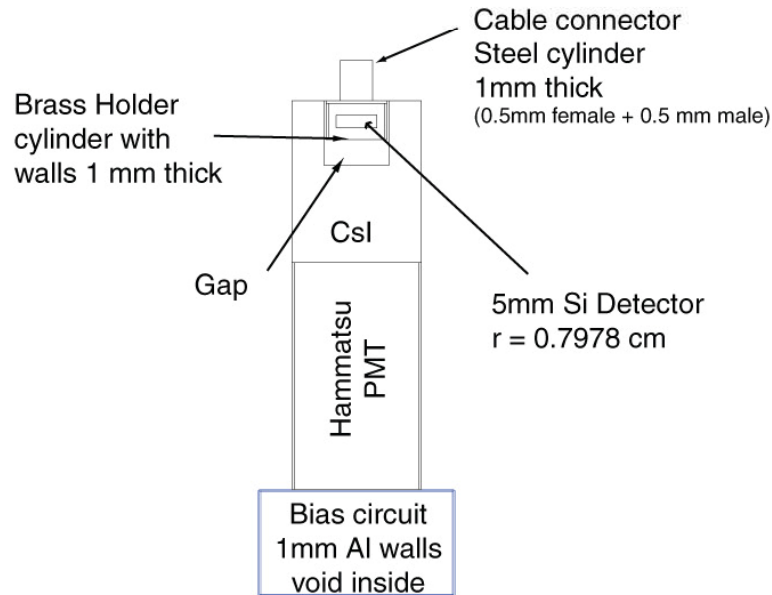

High energy neutron detector in balloon flight box

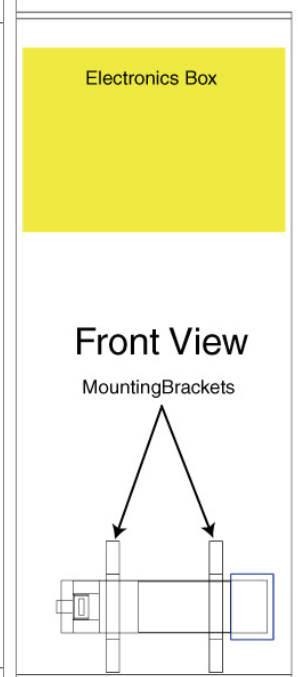

First conceptual simulations for ion spectrometer

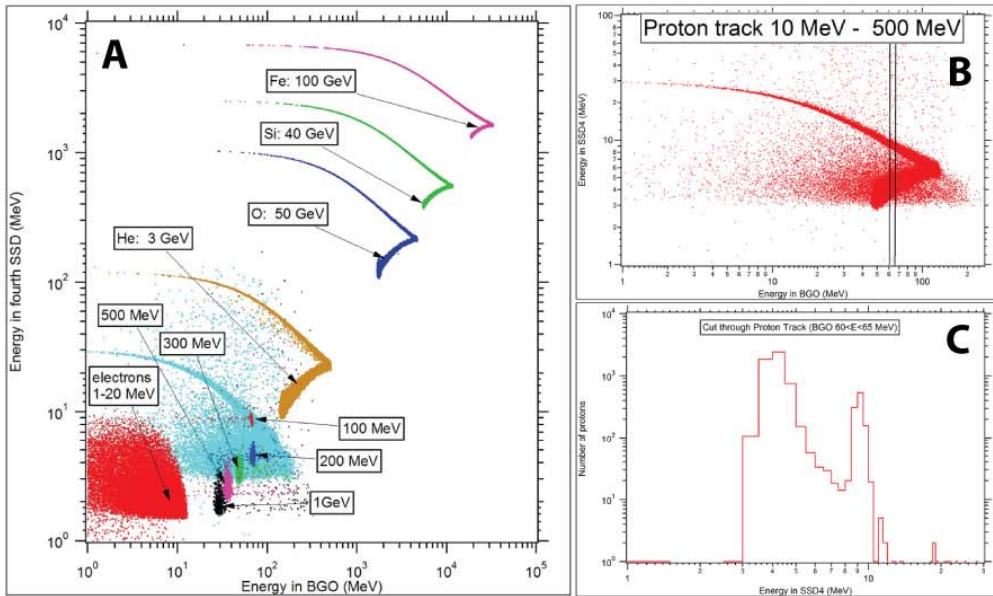

A shows the energy deposition in the thick BGO detector on the abscissa with the energy deposition in the last Si SSD on the ordinate. The vast majority of the protons can be separated from the electrons. With the BGO this simulation shows that protons up to ~300 MeV can be uniquely identified.

B and C show that a proton depositing ~80 MeV in the BGO yields primary and penetrating depositions in SSD4 of 1 MeV resolution.

references:

High-Energy Neutron Spectroscopy with Thick Silicon Detectors

J. D. Kinnison, R. H. Maurer, D. R. Roth and R. C. Haight, *Radiation Research* 159, 154-160, Feb. 2003

Neutron Production from 200-500 MeV Proton Interaction with Spacecraft Materials,

R.H. Maurer, J. D. Kinnison and D. R. Roth, accepted in *Radiation Protection Dosimetry*, 2005

Combined Ion and Neutron Spectrometer for Space Application (CINS)

R.H. Maurer, C. Zeitlin, D.K. Haggerty, D.R. Roth, J.O. Goldsten, 2005 Nuclear Science Symposium, October 24-27, 2005

First conceptual simulations for energetic neutron detector and comparison to balloon flight observations

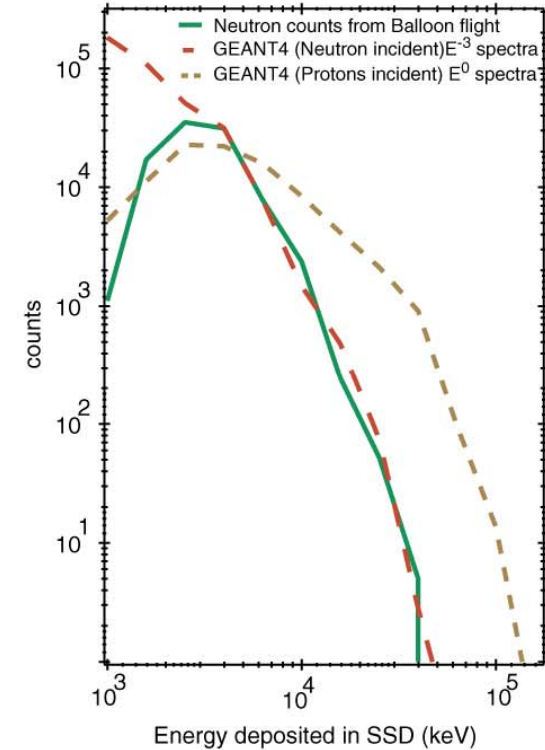

Initial simulations show an incident neutron spectra of E⁻³ matches the balloon flight data.

Significant simulations are underway test the instrument concept, rejection efficiency requirements, and expected rates.

Courtesy of K.Haggerty (JHUAPL)

Planetary scale simulation



Near-Earth regions

- **LOW-EARTH ORBIT (LEO) – Typical ISS orbit**
 - ~ 400 km X 51.6 deg
- **MEDIUM-EARTH ORBIT – Global Positioning Satellite (GPS) Orbit**
 - 20,200 km x 55 deg
- **GEOSTATIONARY ORBIT – 160 deg W long.**
 - ~36,000 km x ~0 deg
- **LEO electron and proton spectra**
 - **AE-8MAX ELECTRON INTEGRAL & DIFFERENTIAL**
 - **AP-8MIN PROTON INTEGRAL & DIFFERENTIAL SPECTRA**
 - **ISS ORBIT: 400 KM, 51.6 DEG**
 - Current standard NASA AE8/AP8 models of Earth's radiation belts have known limitations, mostly due to limited range of (1960s) observations incorporated
 - Some energies and spatial regions were not sampled, so extrapolation needed
 - Only simple (MIN/MAX) account taken of dependence on 11-year solar cycle

GEO Electron Dose Comparisons - 1

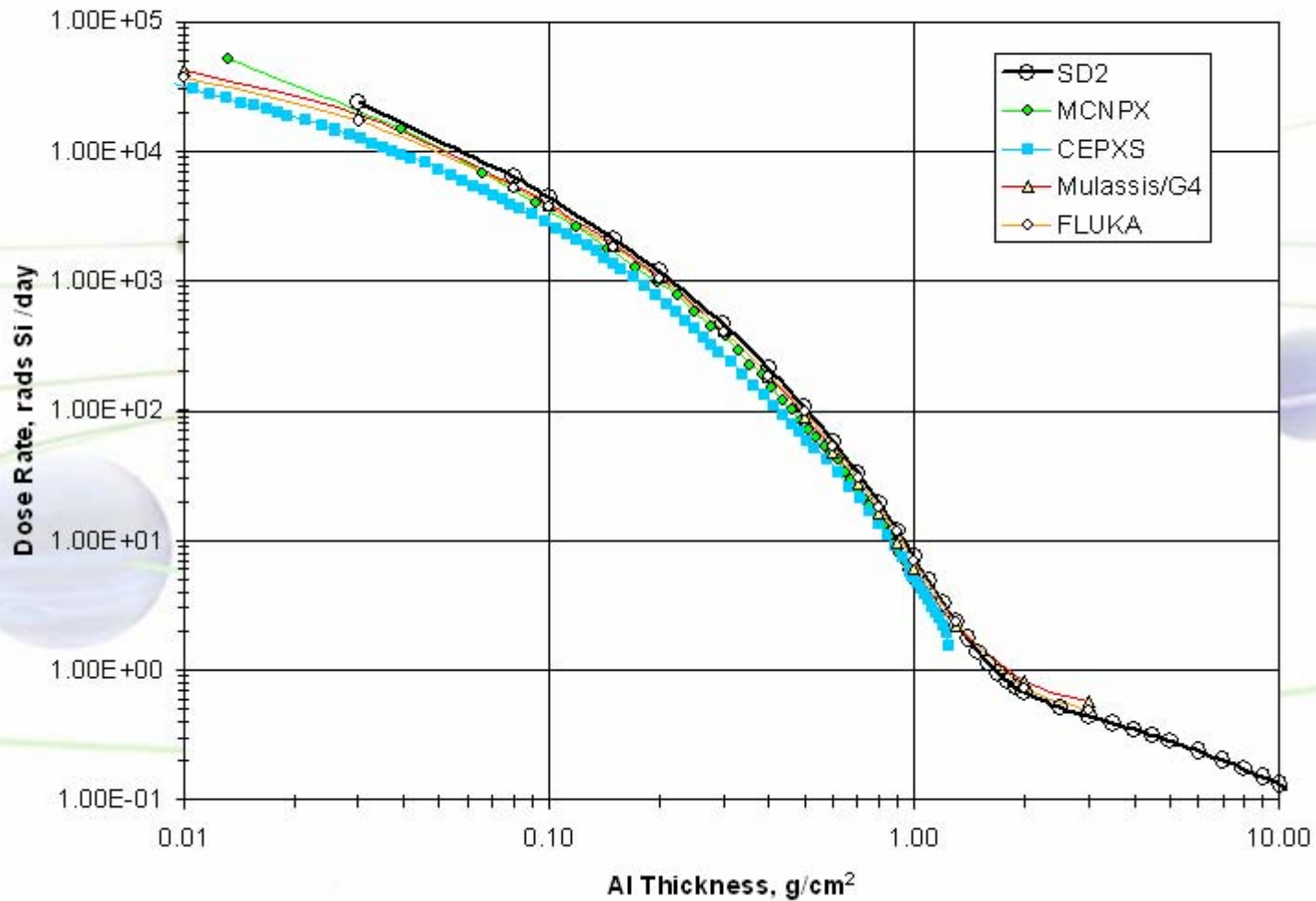

15

Courtesy of B.Reddel (Boeing)

LEO Proton Dose Comparisons

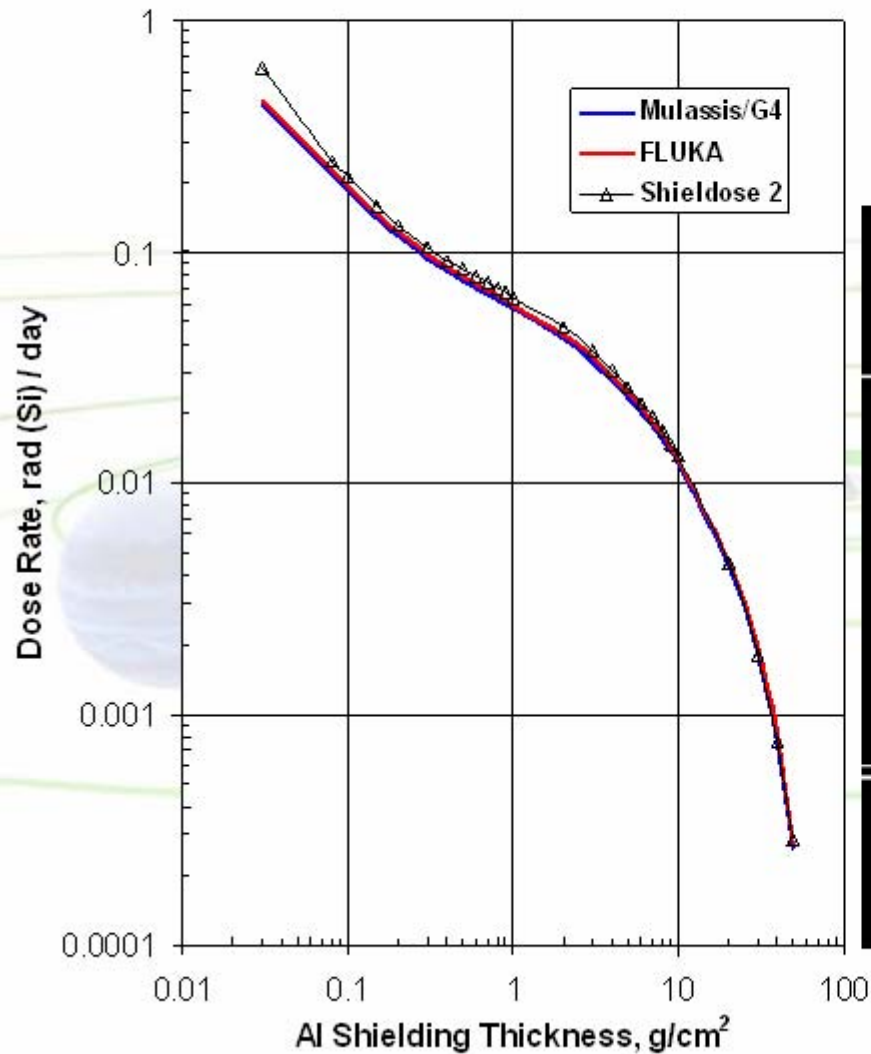

200 MeV Proton
incident on 1.0 g/cm²
Aluminum Slab

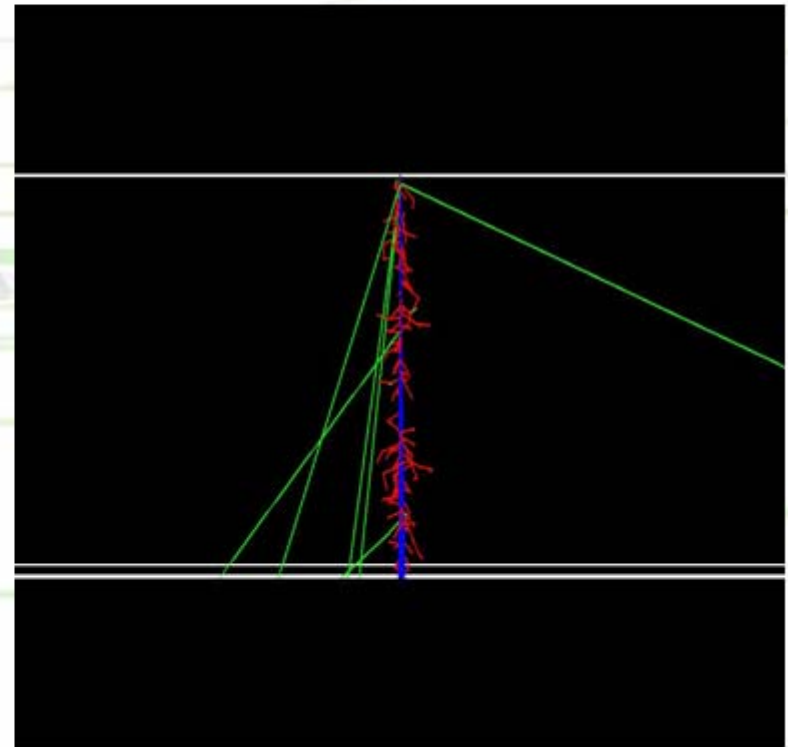

12

Courtesy of B.Reddel (Boeing)

LEO Electron Dose Comparisons

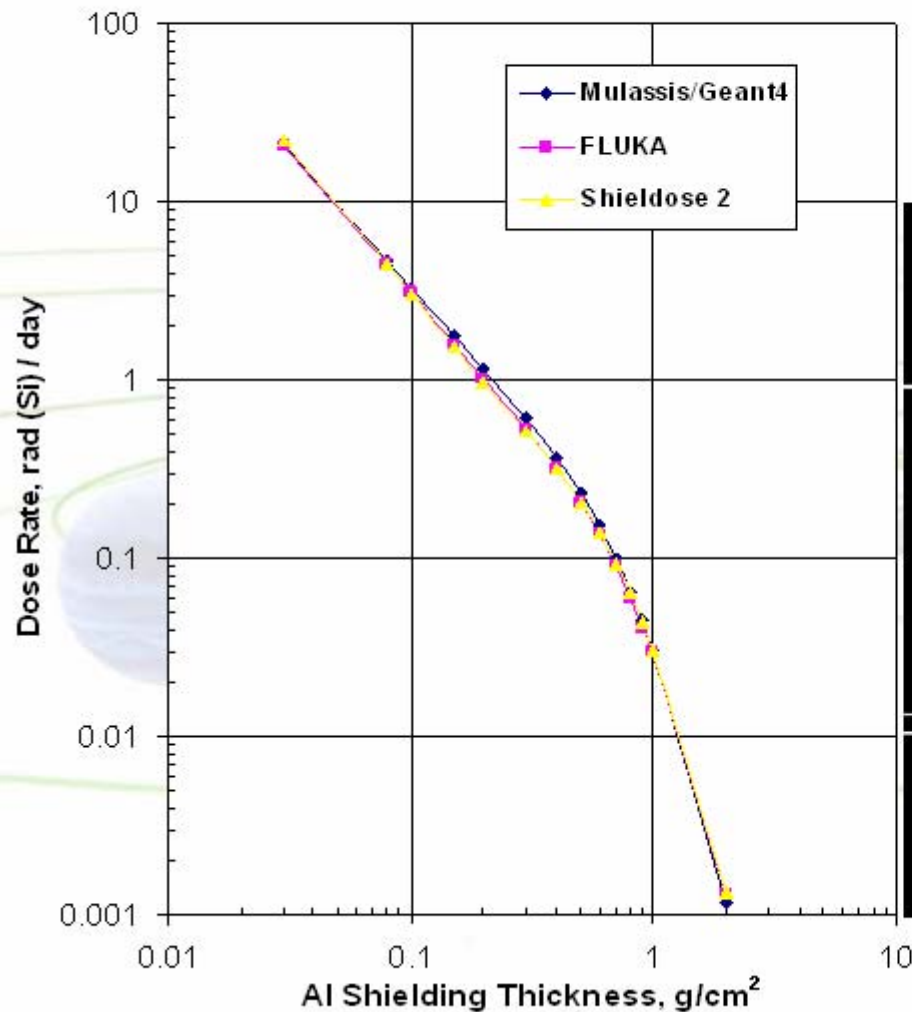

1.0 MeV Electron
incident on 1.0 g/cm^2
Aluminum Slab

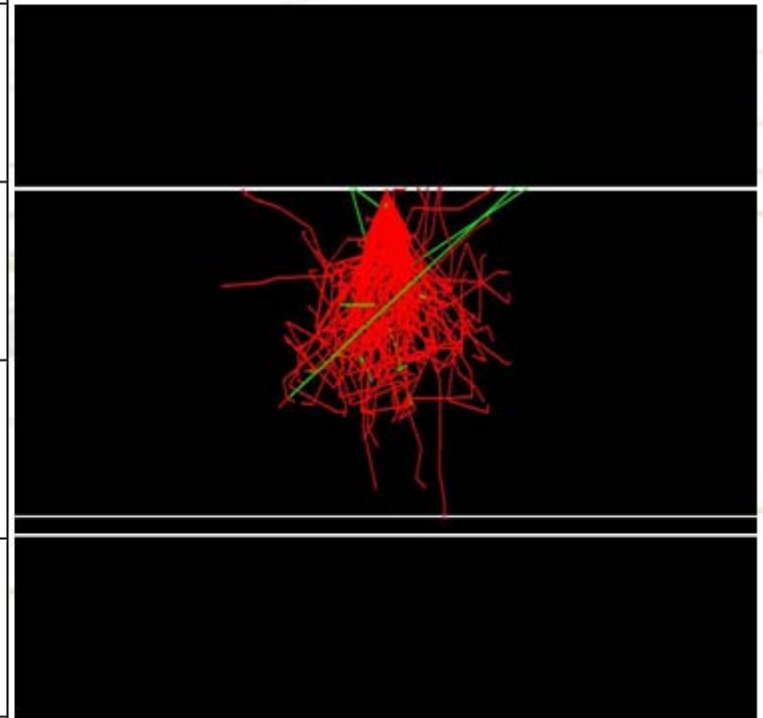

13

THE GLOBALIZATION of the
ANT4
ts

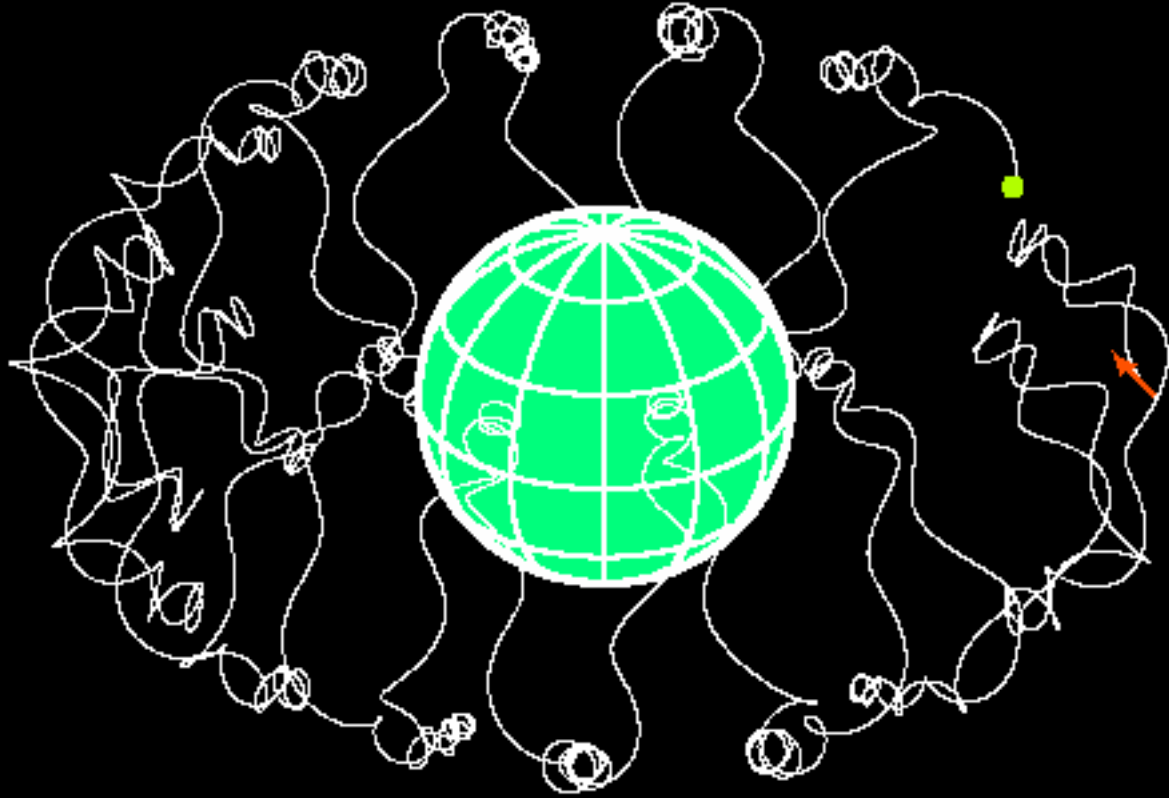

oper
, CA USA

A

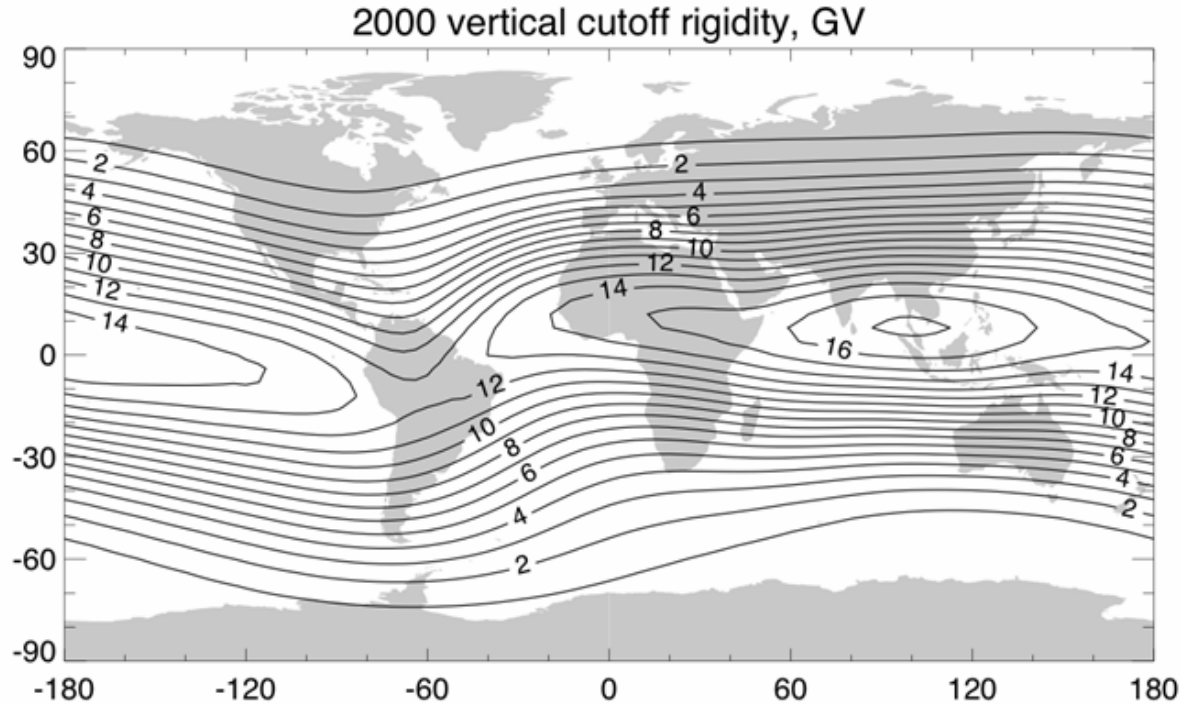

- Source: Cosmic Ray Albedo Neutron Decay (CRAND)
- Cosmic ray protons modulated by solar activity (F10.7), e.g., Usoskin et al. 2002
- Geomagnetic access to atmosphere modeled using vertical rigidity cutoff plus transmission function to account for off-vertical variation

Courtesy of M.D.Looper (Aerospace Corp.)

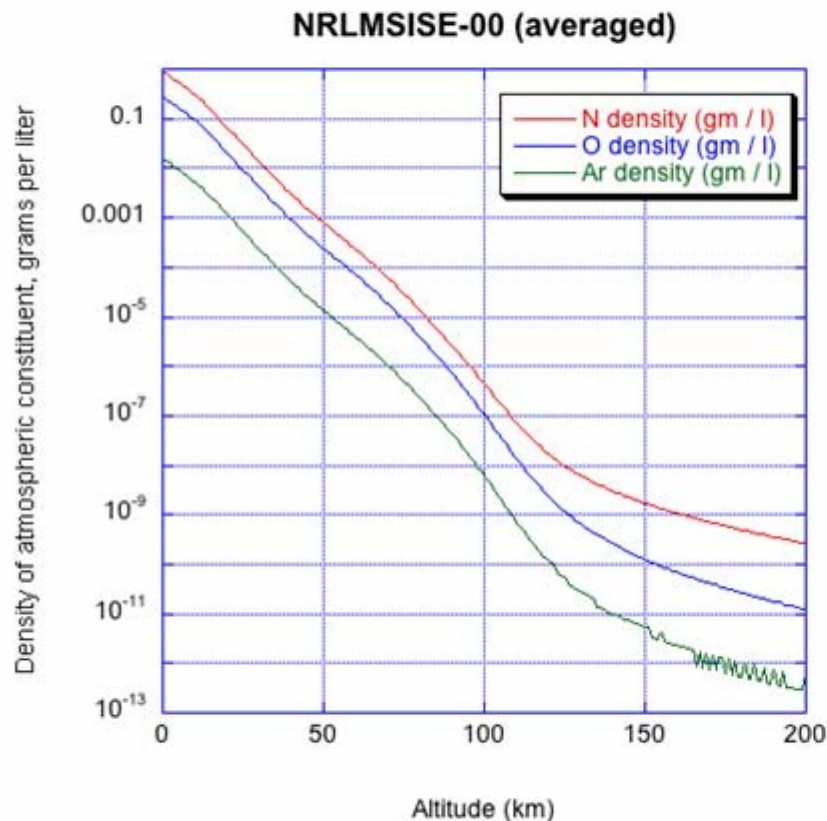

- Monoenergetic protons incident isotropically at 200 km altitude
- Atmosphere modeled with average of NRLMSISE-00 N, O, and Ar densities over latitude, longitude, local time, and season, with typical geomagnetic conditions: F10.7 = 150, Ap = 4 (Picone et al. 2002)
- GEANT4 physics list LHEP_PRECO_HP seemed reasonable...
- Neutrons exiting top of simulation tabulated
- Mac OS X, dual 2.5GHz G5

Courtesy of M.D.Looper (Aerospace Corp.)

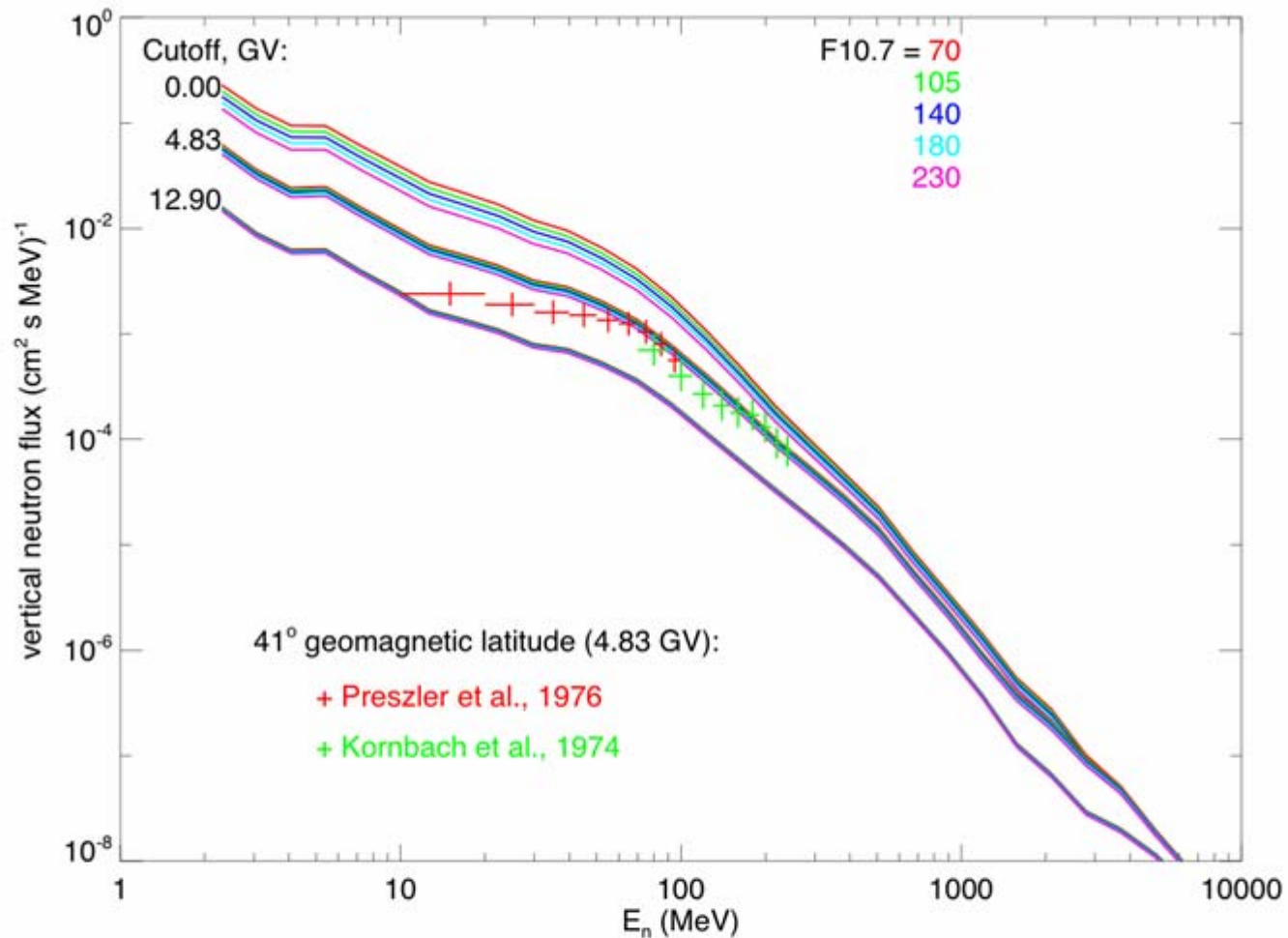

- Neutron production convolved with incident modulated/cut-off proton spectrum
- Agreement with observations pretty good, especially at crucial higher energies

Courtesy of M.D.Looper (Aerospace Corp.)

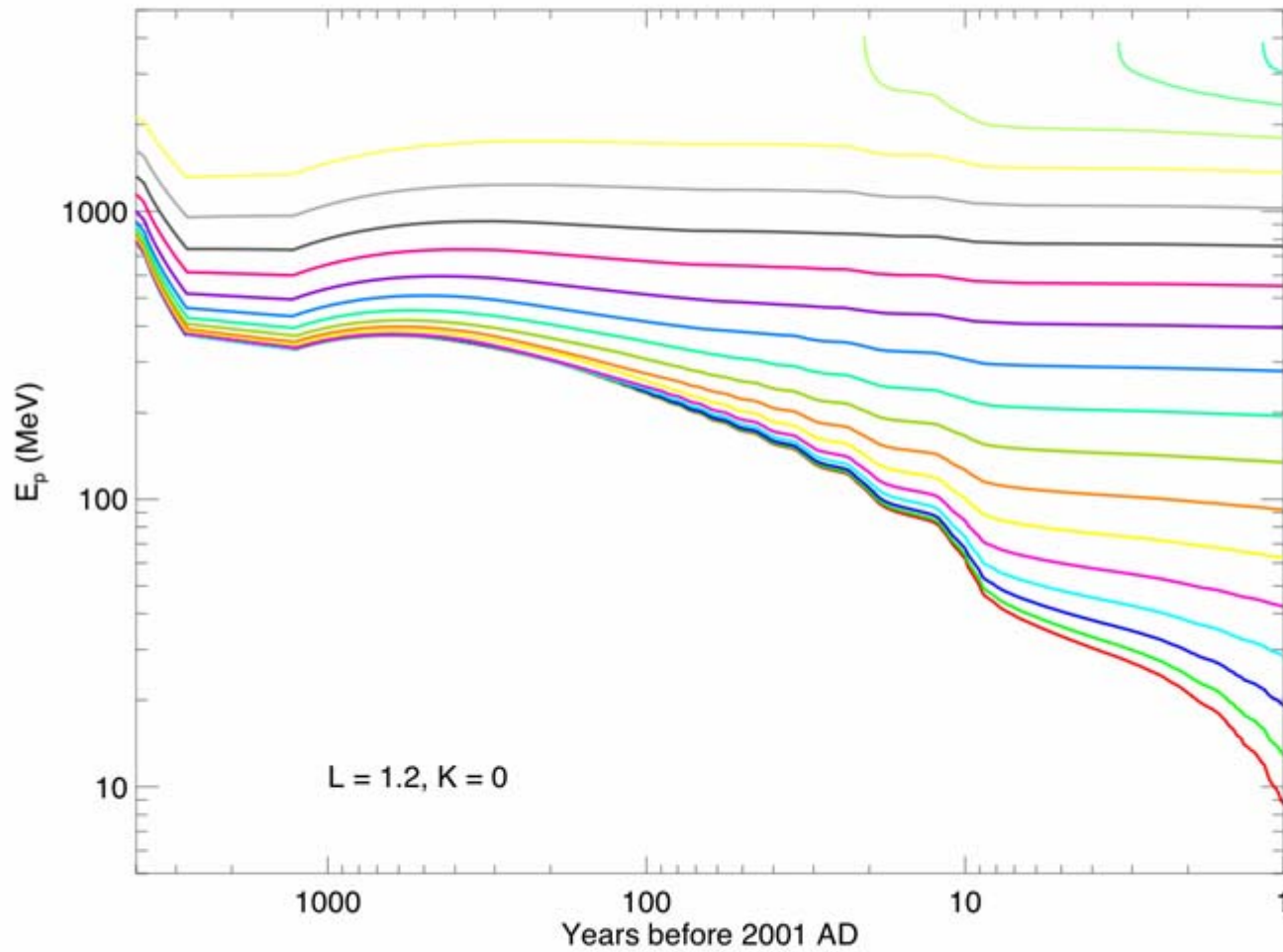

Courtesy of M.D.Looper (Aerospace Corp.)

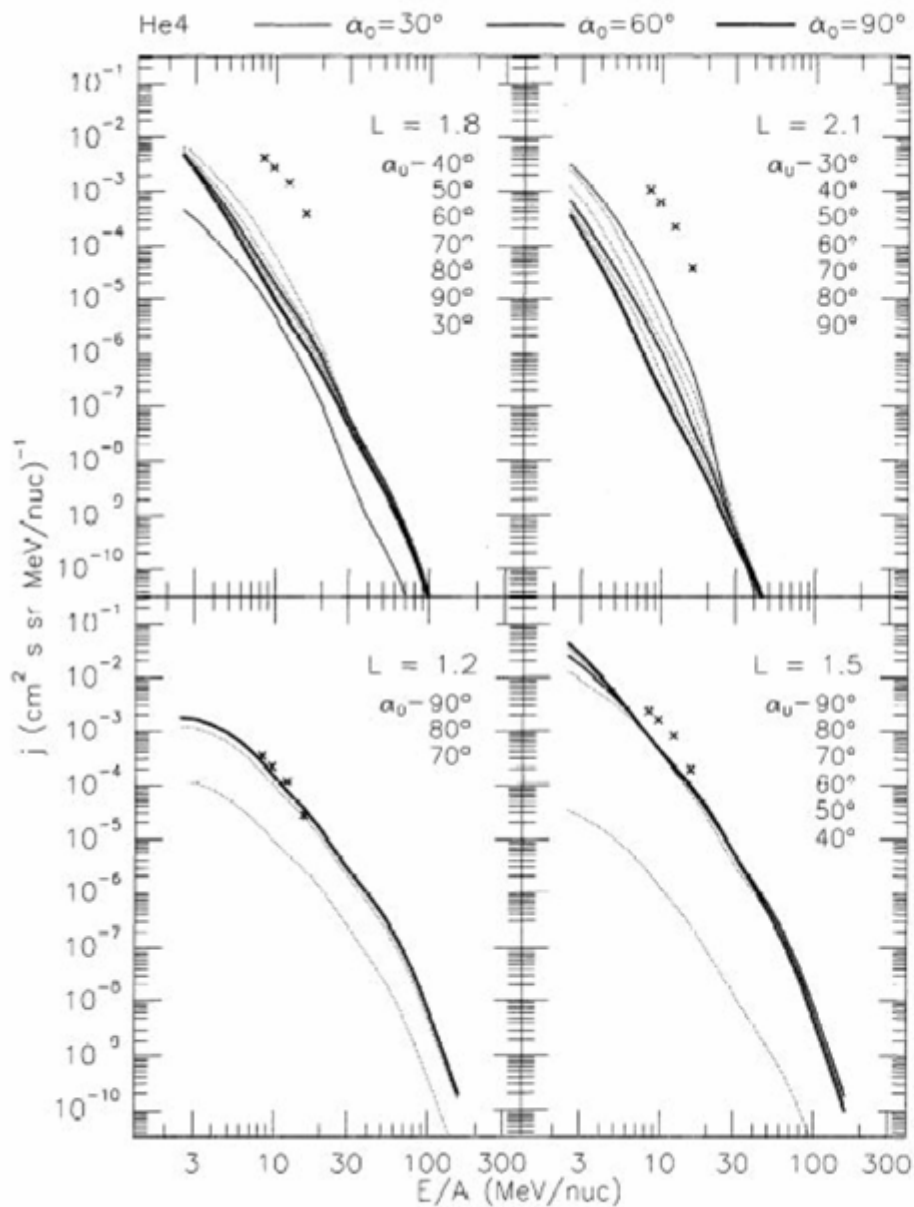

- Other improvements include addition of neutrons from cosmic-ray helium to CRAND source (about 10% of proton incident flux, but higher yield)
- Light-ion secondaries (deuterium, tritium, alphas and helium-3, e.g., Looer et al. 1996) have been observed and modeled (with AP8 inputs), Selesnick & Mewaldt 1996
- Both of these, as well as nuclear scattering of protons off atmospheric and exospheric nuclei, require GEANT4

Courtesy of M.D.Looer (Aerospace Corp.)



Micro-dosimetry simulation

CCD Image of the Sun

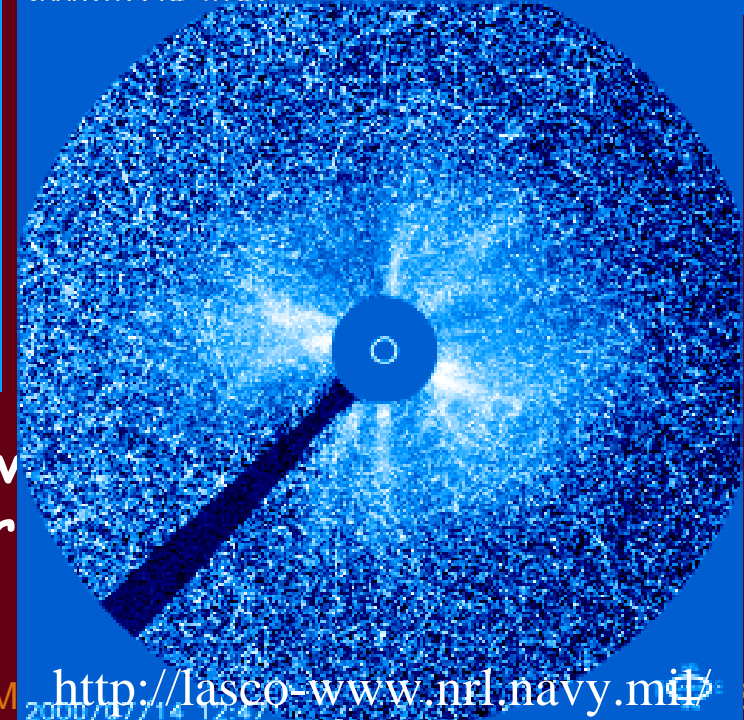
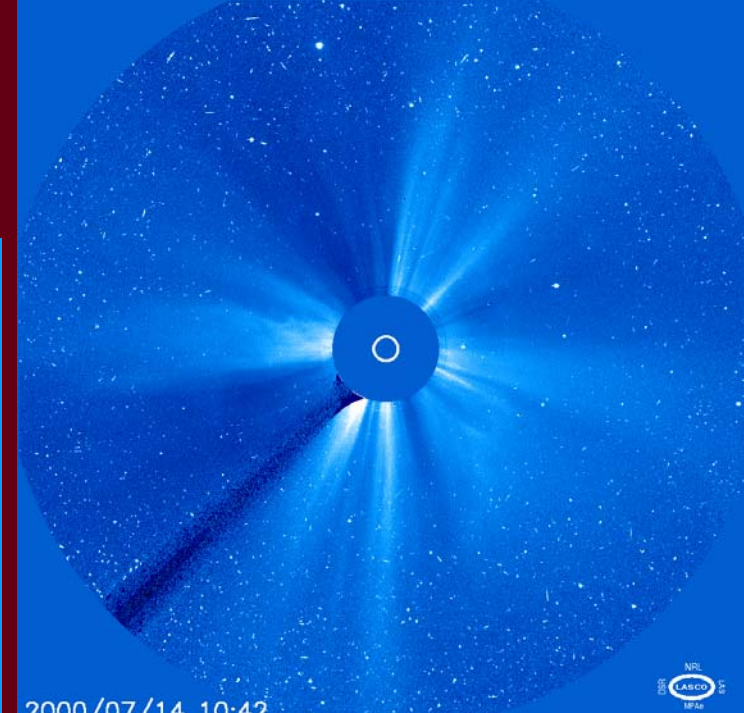
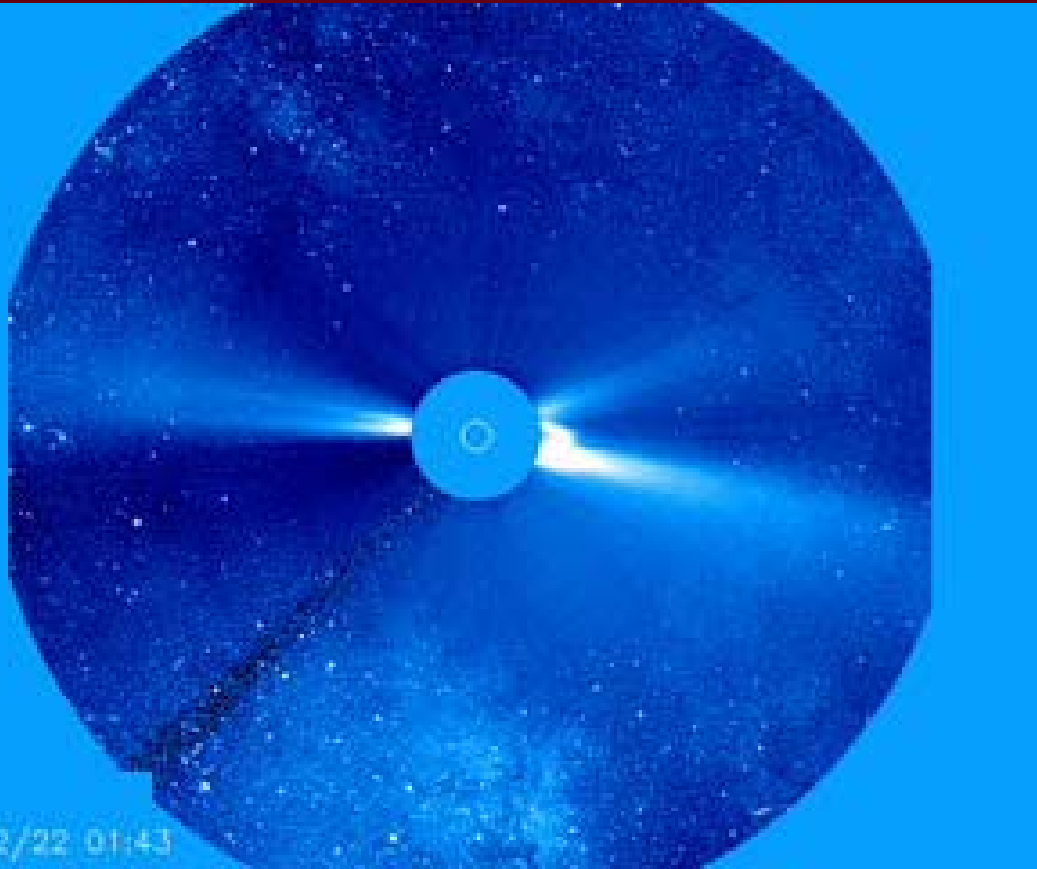

Solar and Heliospheric Observations
Large Angle and Spectrometric Coronagraph

<http://image.gsfc.nasa.gov/poetry/movies/movies.html>

Geant4 Applications in NASA Space Missions - M <http://lasco-www.nrl.navy.mil/>

Low Noise Quantitative Detection Across the Spectrum

- Ground-based Radio Astronomy
- Microwave looks at the Cosmic Microwave Background
 - COBE, FIRS, WMAP
- Mid to long wave IR (>5 mm)
 - SIRTF, JWST
- Near Infrared
 - HST - WFC3 & NICMOS
- Visible (panchromatic)
 - HST - WFPC2, ACS, WFC3
- Near uV to VuV (solar phys)
 - SOHO, SDO, STEREO
- x-ray
 - CHANDRA, XMM-Newton
- γ -ray
 - GRO, GLAST, RHESSI
- Gravity wave - Laser Interferometer Space Antenna - LISA

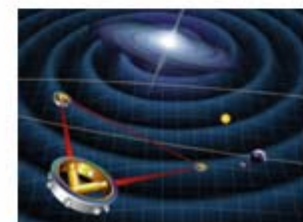
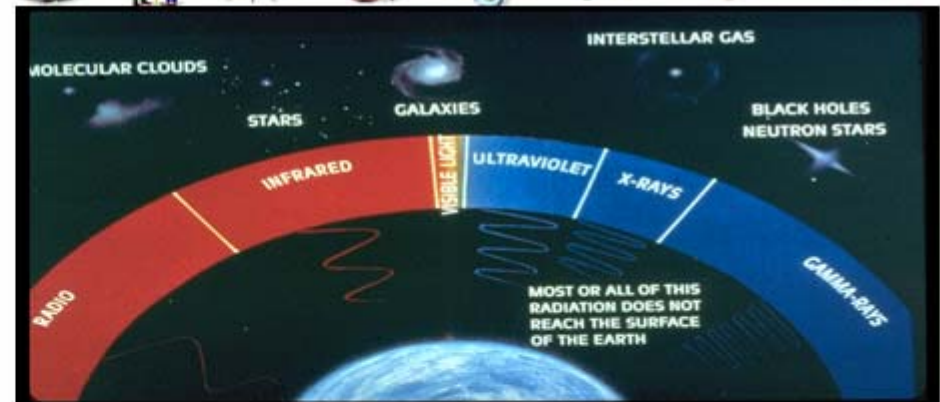
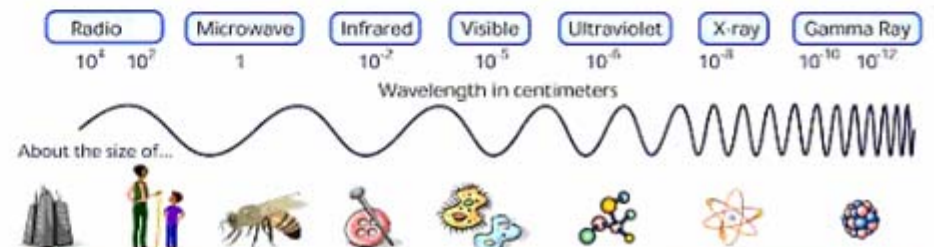

Application of the RADSAFE Concept

Vanderbilt University

R.A. Reed, R.A. Weller, R.D. Schrimpf, L.W. Massengill,

NASA/GSFC

K.A. LaBel

SLAC

M. Asai, D.H. Wright, T. Koi



Space Radiation Environment

Three portions of the natural space environment contribute to the space environment effects hazard

- Solar particles
 - Protons and heavier ions
- Galactic Cosmic Rays (GCR)
 - For earth-orbiting craft, the earth's magnetic field provide some protection for GCR
- Trapped particles (in the belts)
- Hazard observed is a function of orbit and timeframe
- Environment is dynamic, models are static

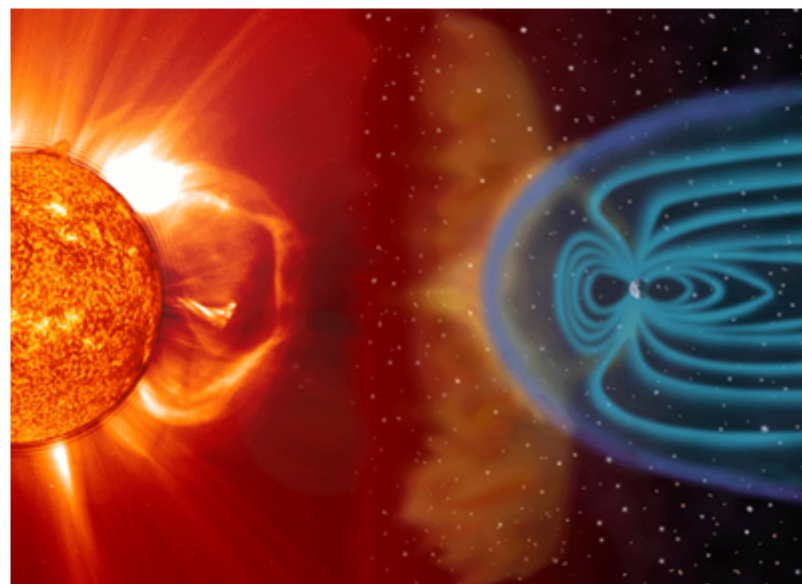

ISS Single Event Upset Observations

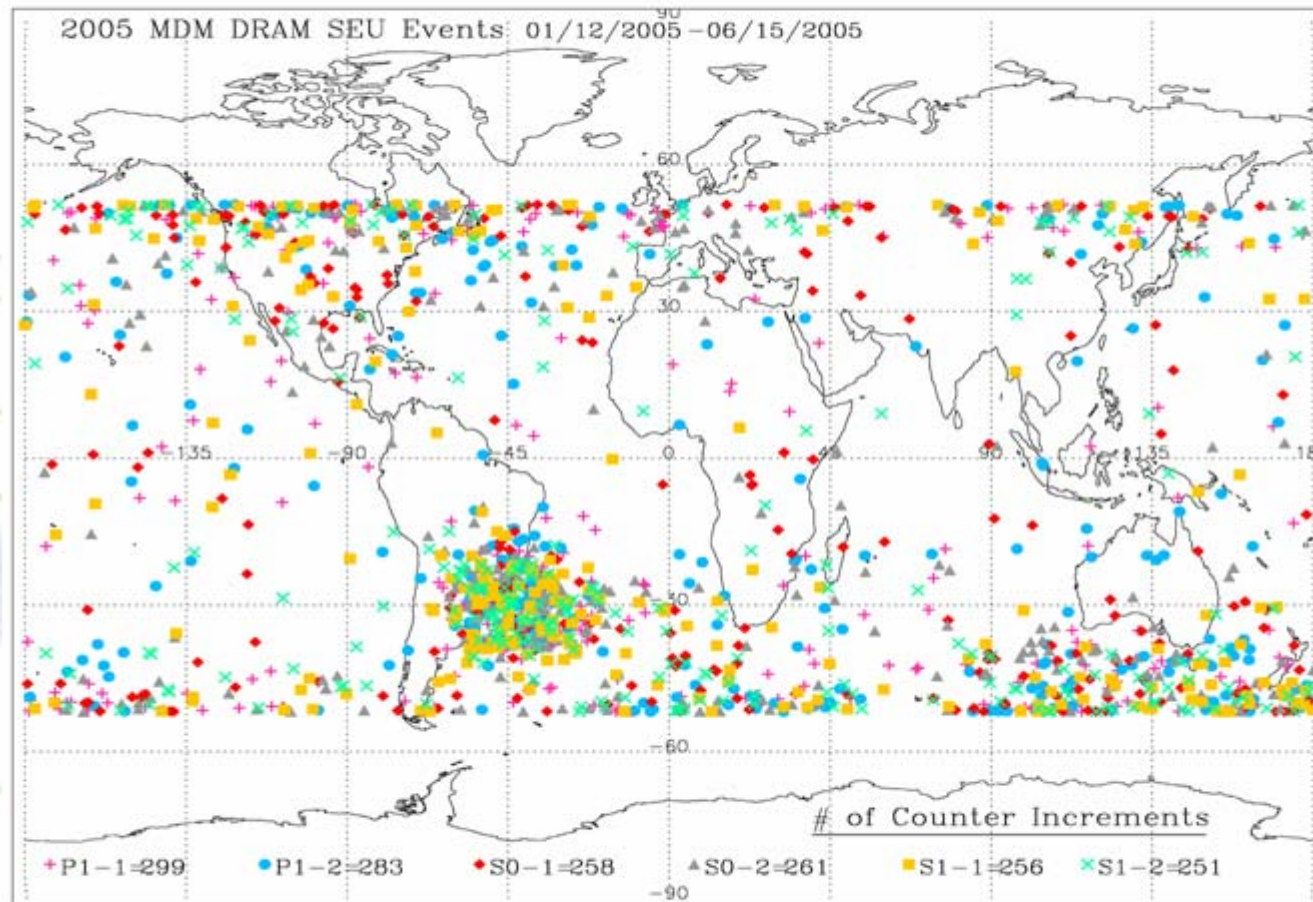

18

ISS Single Event Upset Observations

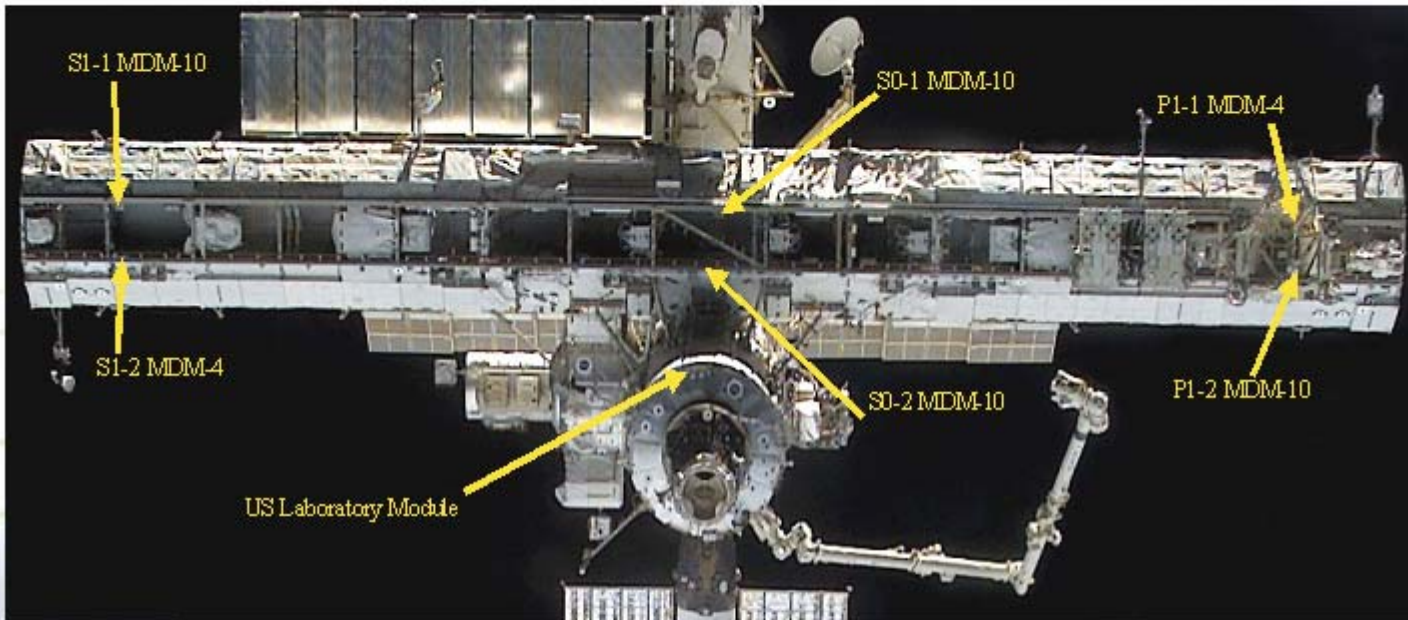

MDM-DRAM	Measured SEU Count/238 days	SEFA SEU Count/238 days	FOM SEU Count/238 Days
Lab-1 40 g/cm ²	488	287	83
Lab-3 40 g/cm ²	490	287	83
P1-2: 10 g/cm ²	536	6202	1647
S1-1: 10 g/cm ²	488	6202	1647

19

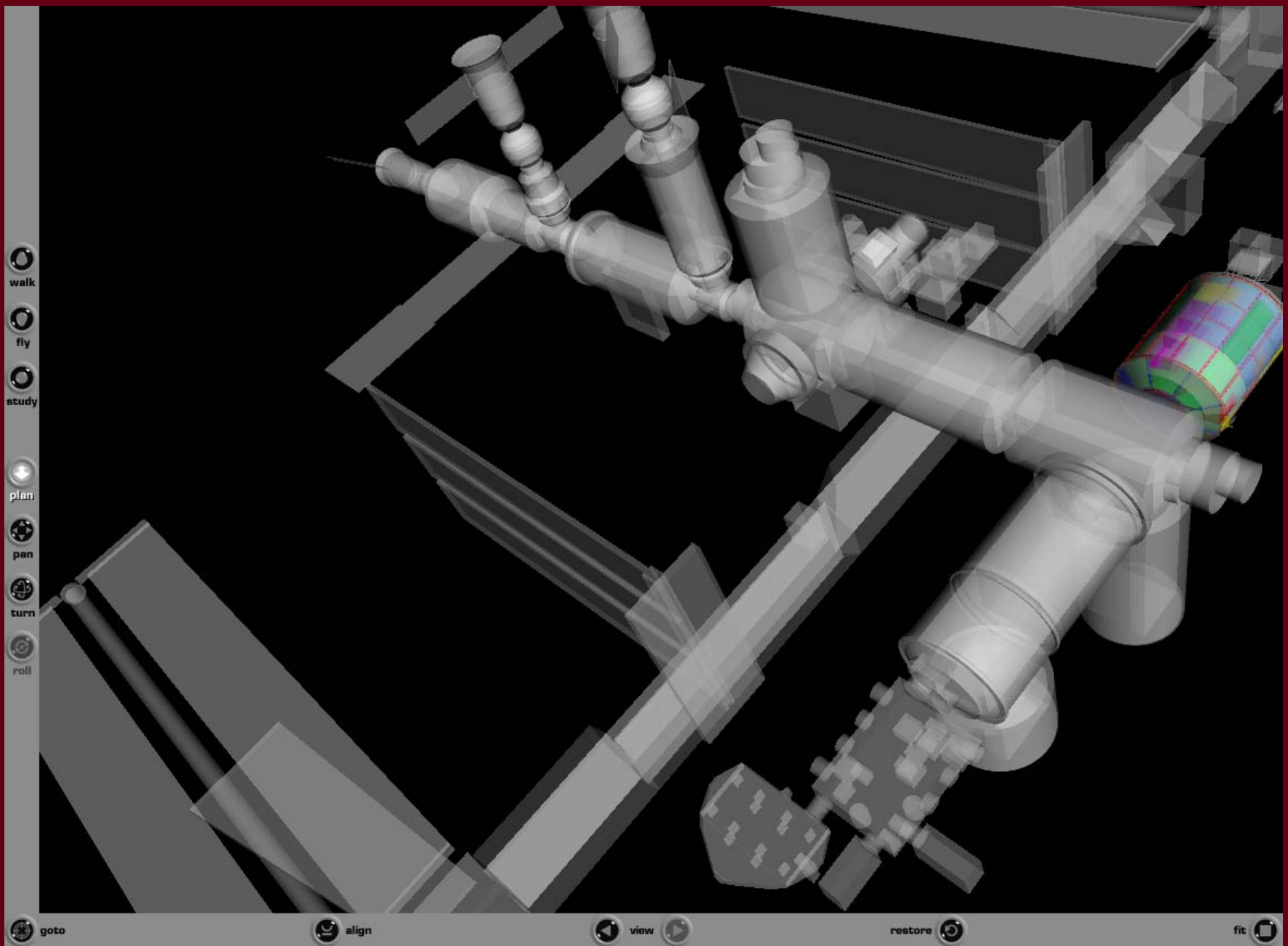

Single Event Effects

Two Ionization Cases:

- ☀ Incident particle generates electron-hole (e-h) pairs

Direct



- ☀ Secondary particles add to generated e-h pairs

Indirect

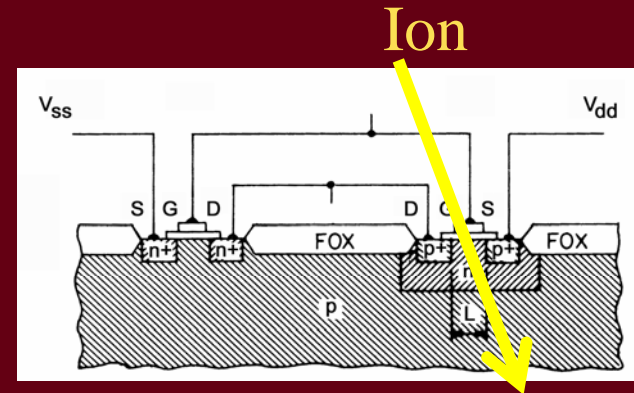
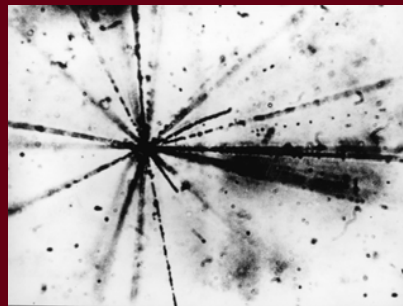

Charge collected on a sensitive node in an electrical circuit causing an unwanted change in information stored on the component

- Single Event Upset
- Single Event Latchup
- Single Event Transient
- Single Event Gate Rupture
- Single Event Functional Interrupt
- Single Event ...

P.J McNulty, Notes from 1990 IEEE Nuclear and Space Radiation Effects Conference Short Course

Single Event Effects

● Two Ionization Cases:

- ☀ Incident particle generates electron-hole (e-h) pairs

Direct



- ☀ Secondary particles add to generated e-h pairs

Indirect

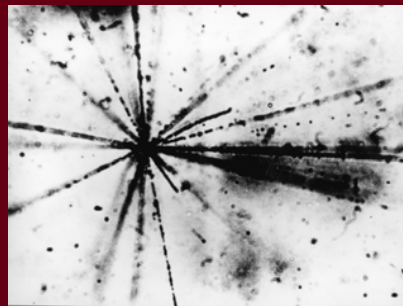

P.J McNulty, Notes from 1990 IEEE Nuclear and Space Radiation Effects Conference Short Course

● SEE modeling challenges we are currently addressing with RADSAFE:

- ☀ Detailed device and circuit response

- Technology Computer Aided Design (TCAD) + Geant4 + spice

- Commercial tools unable to predict indirect ionization case

- ☀ On-orbit rate prediction

- Approximation methods

- Failure of models when applied to emerging technology

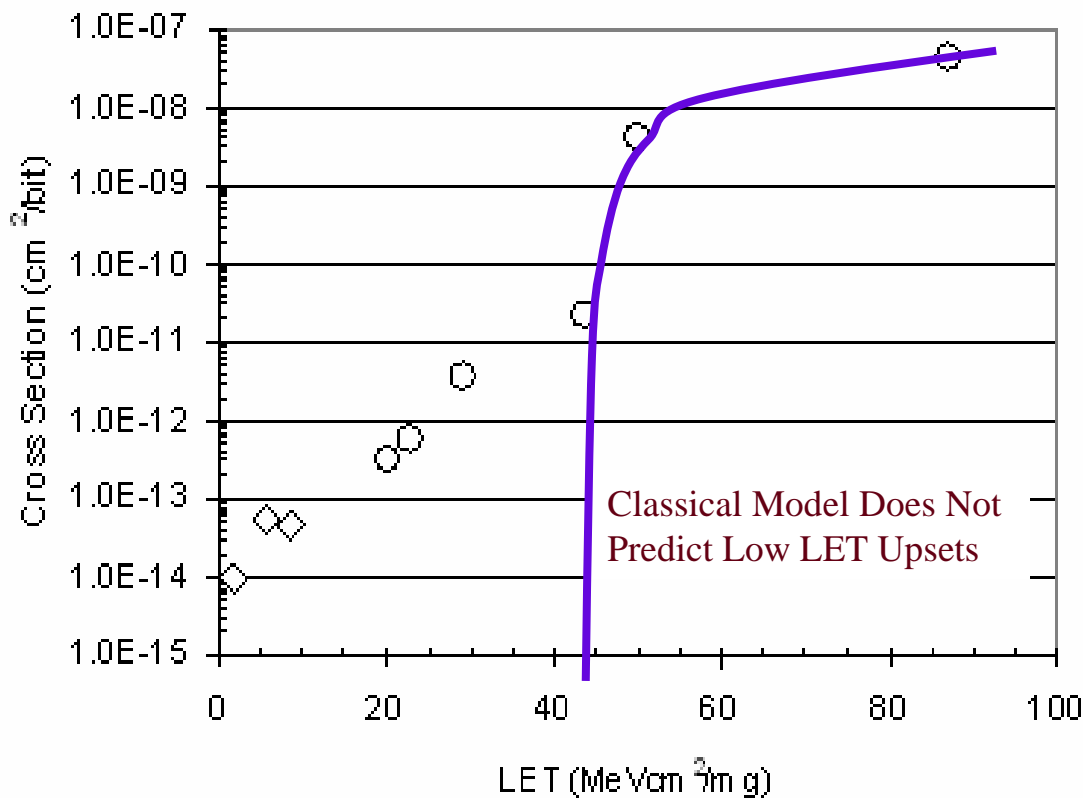

Ionization SEE Rate

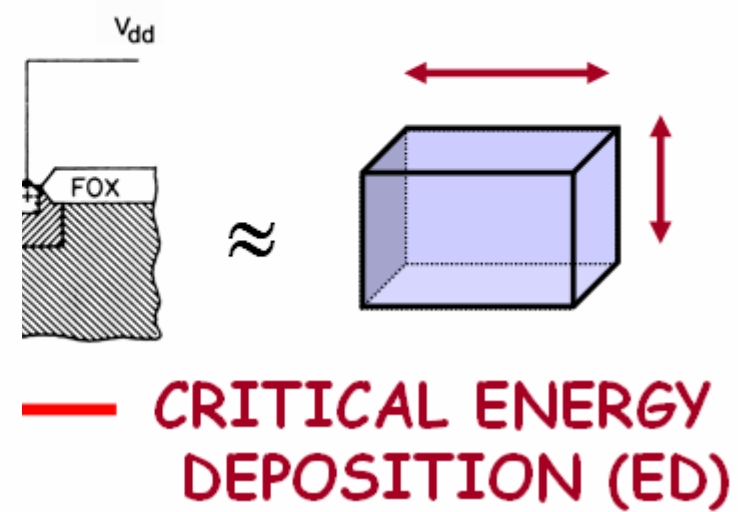

≡ On-Orbit Rate =

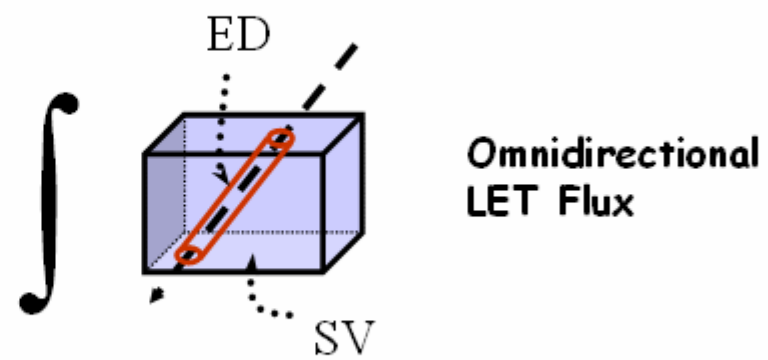
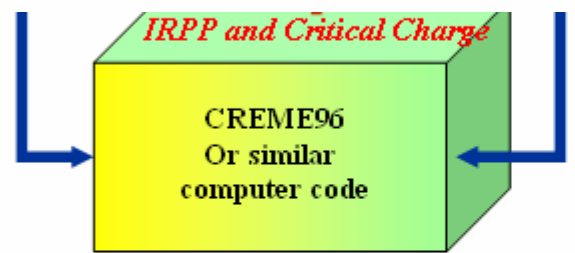

Linear Energy Transfer (LET) - a measure of the energy deposited per unit length as a energetic particle travels through a material.

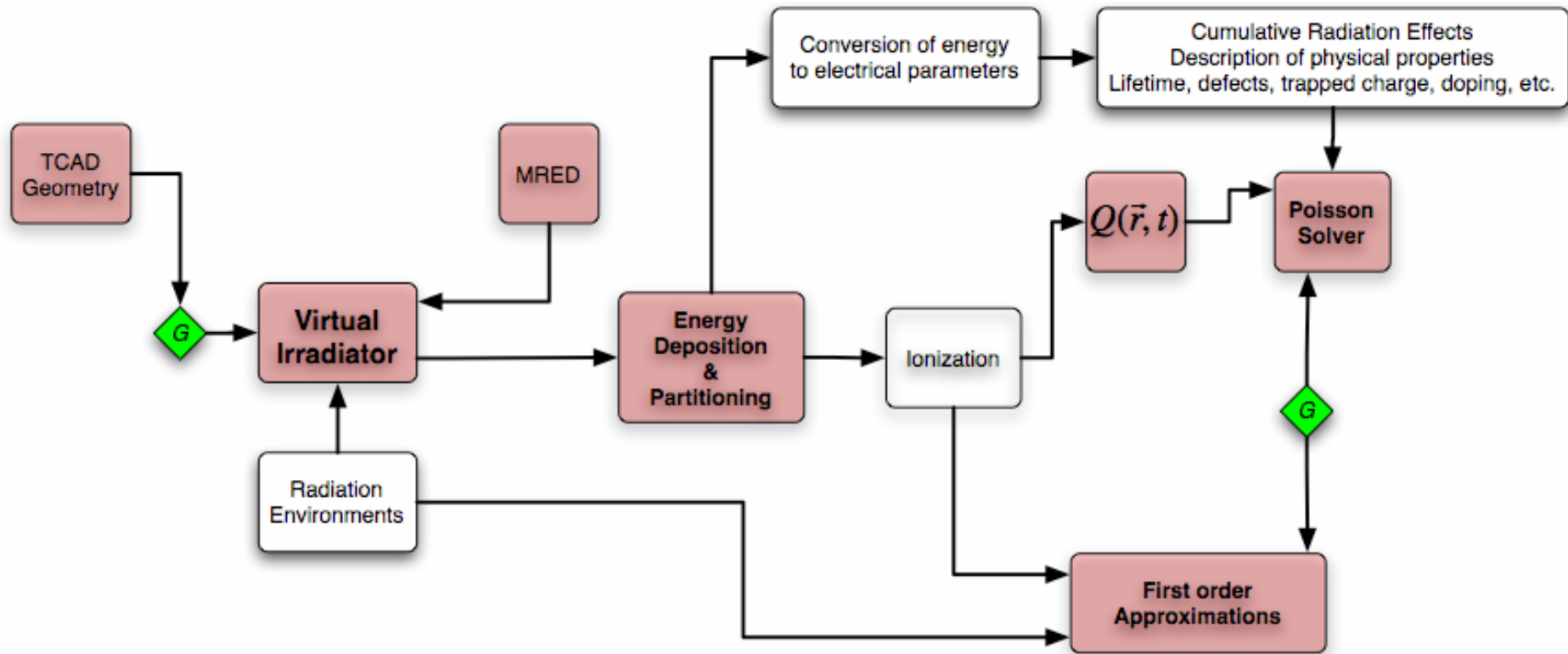

MRED - Monte Carlo Radiative Energy Deposition tool

- Developed at Vanderbilt University
- Based on Geant4
- Run time selectable physics list
- Python interface
- Highly Flexible output

Example #1: SEUs in SRAMs

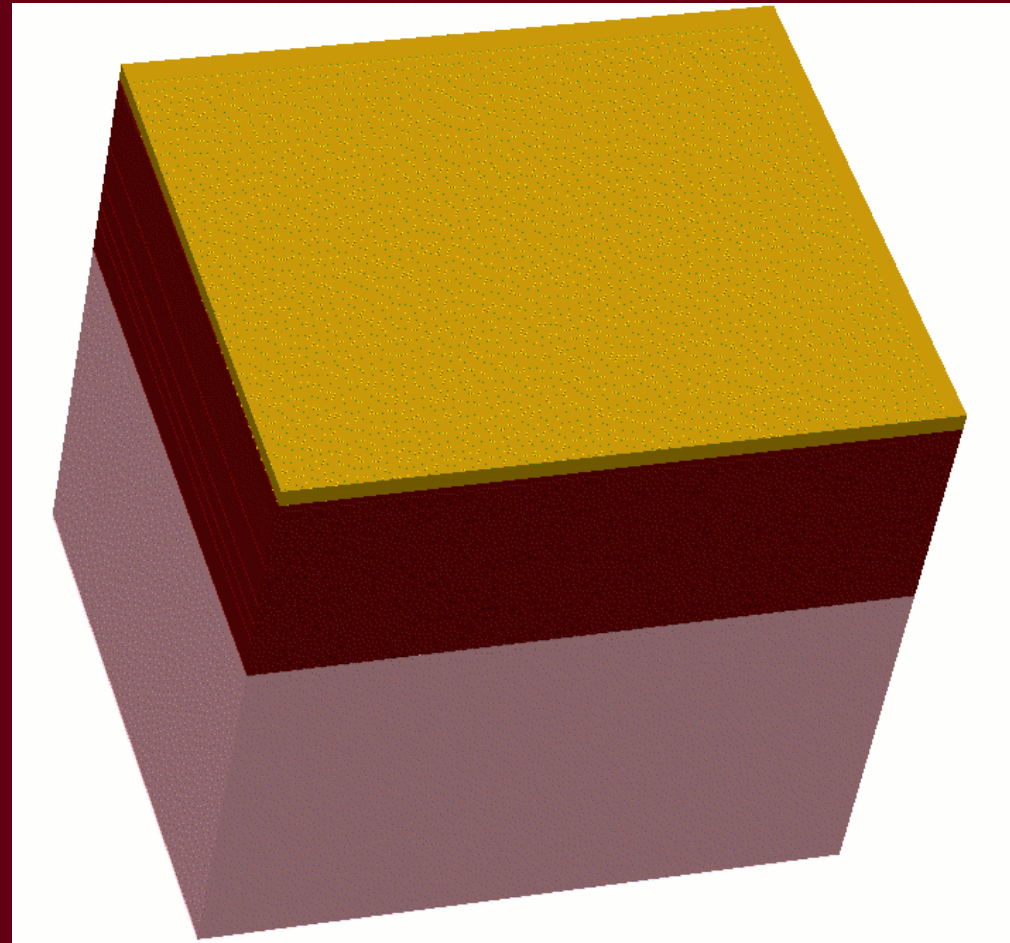

Single Event Simulation

- Structure: Si diode, a 5 μm cube.
- Events: 10^6 1 GeV/nucleon ^{12}C .
- Pre-selection:
 - >1.5 MeV in a 1 μm cube,
 - 0.5 μm below the junction.
 - 267 candidate events.

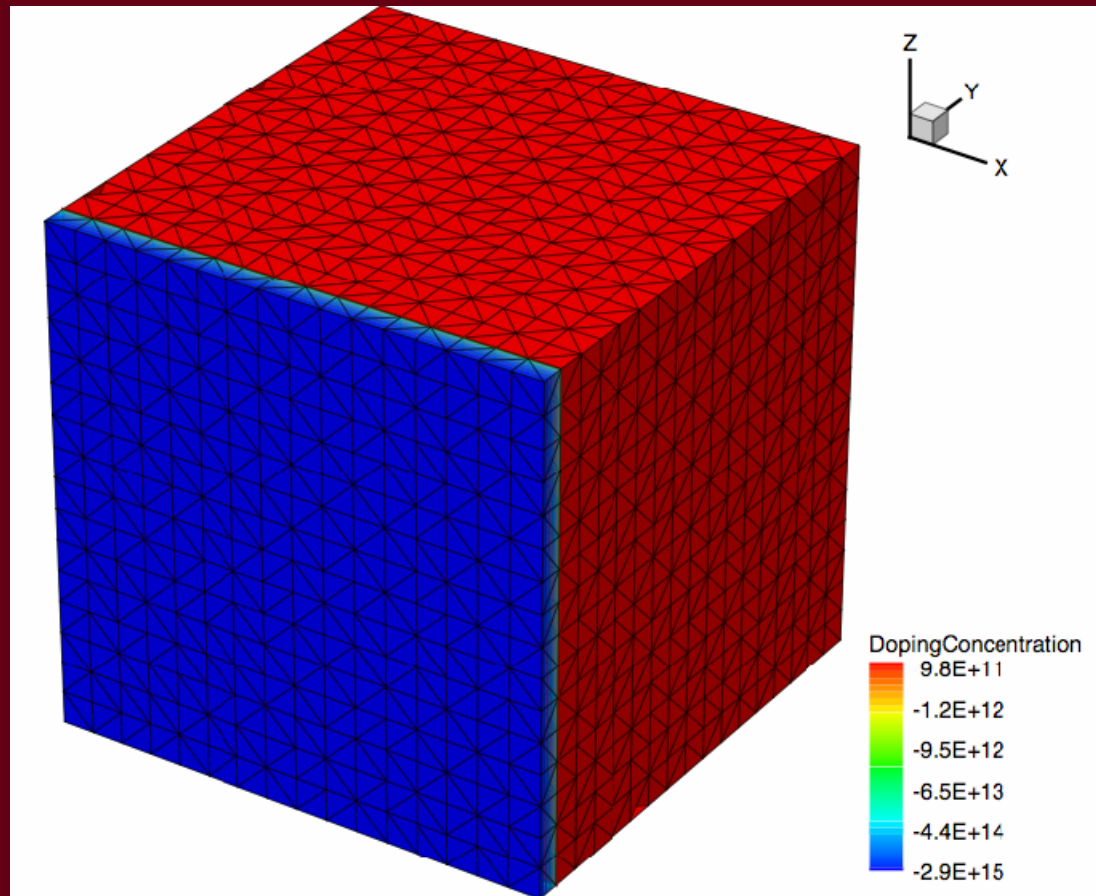

Ion Tracks

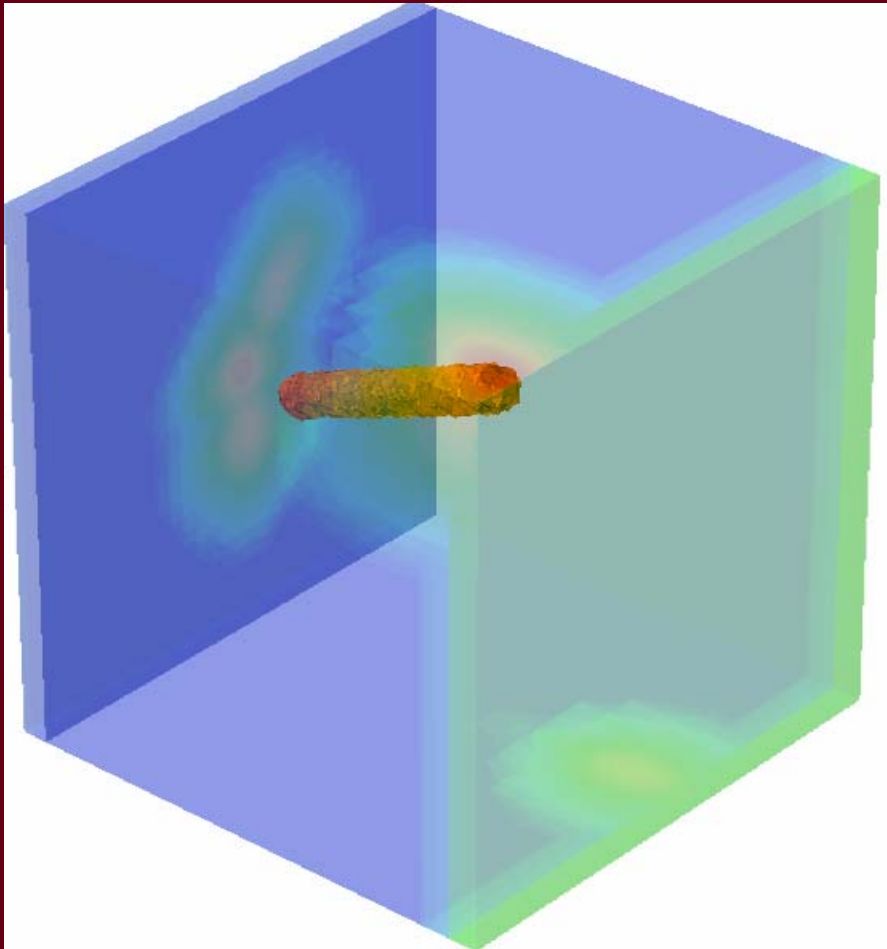

$10^{18} \text{ e}^-/\text{cm}^3$

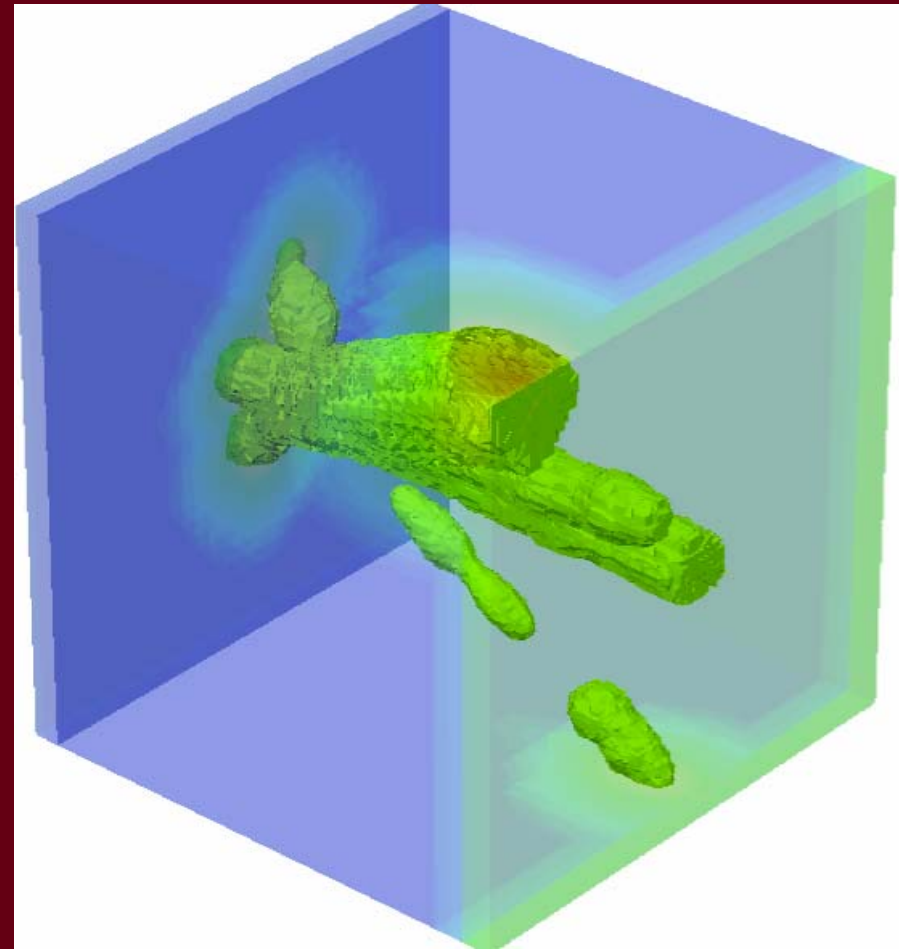

$10^{14} \text{ e}^-/\text{cm}^3$

Radiation event: Meshing

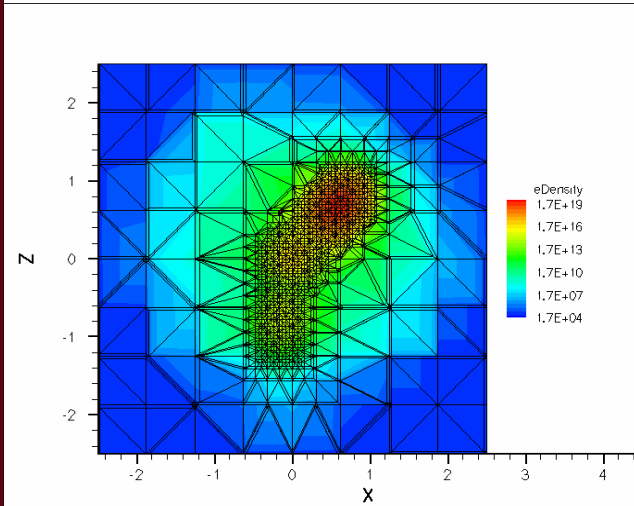
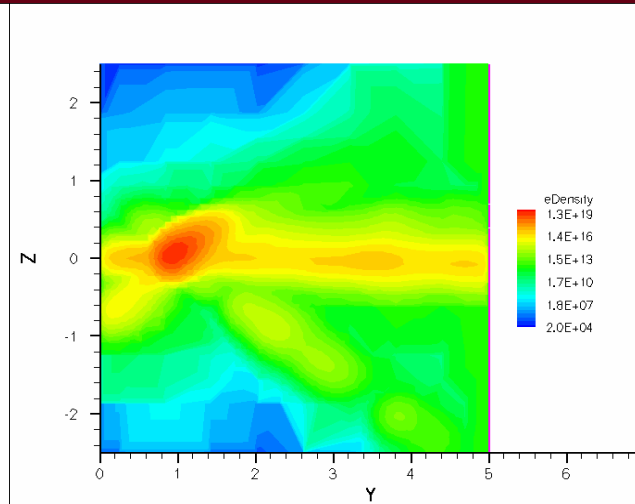
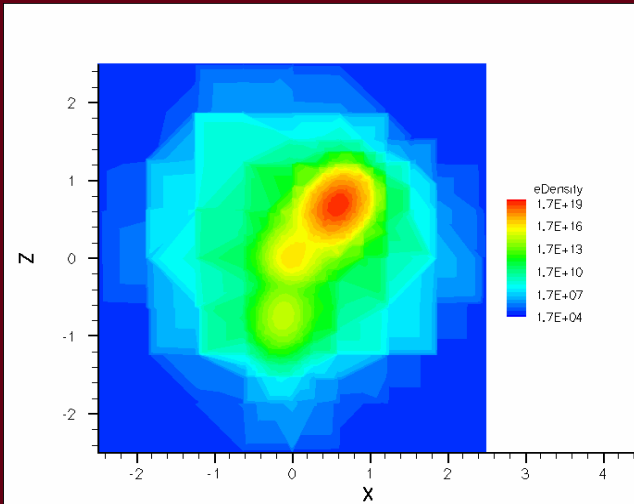

Slice at $y = 1.0 \mu\text{m}$

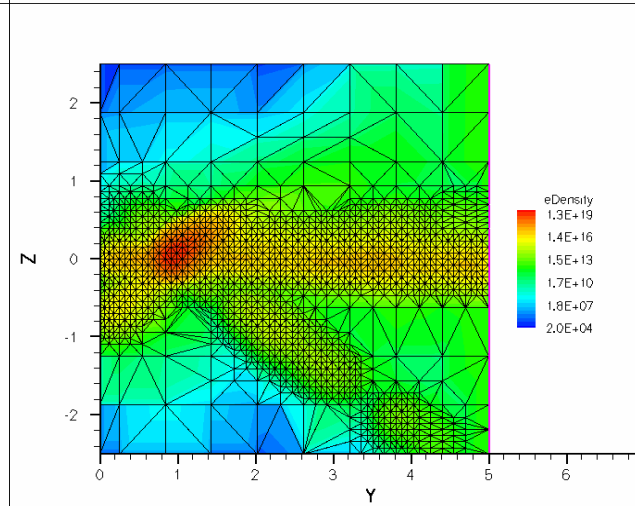

Slice at $x = 0 \mu\text{m}$

TCAD simulation of radiation event

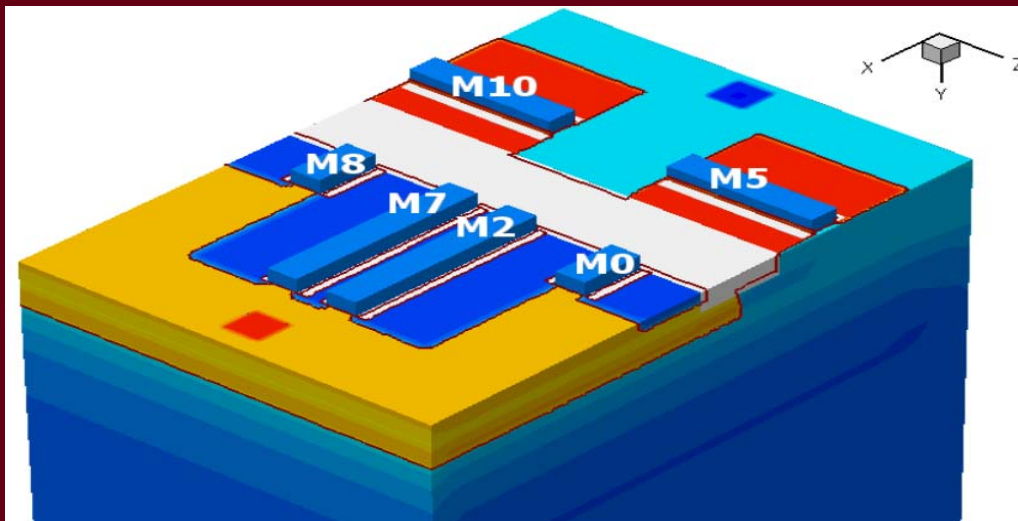
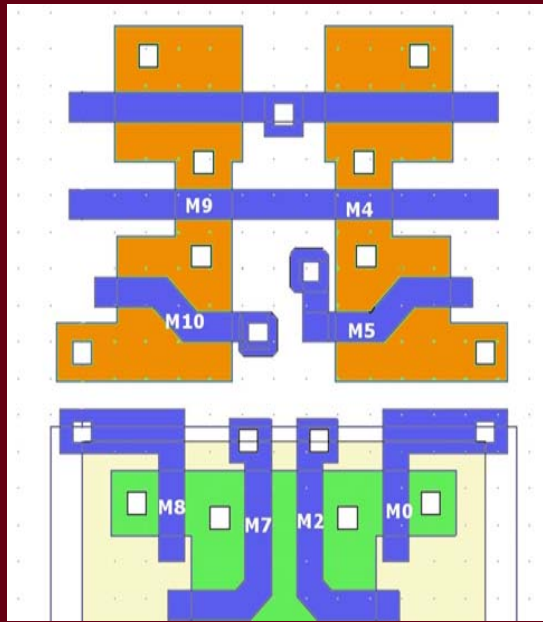

TCAD simulation of radiation event

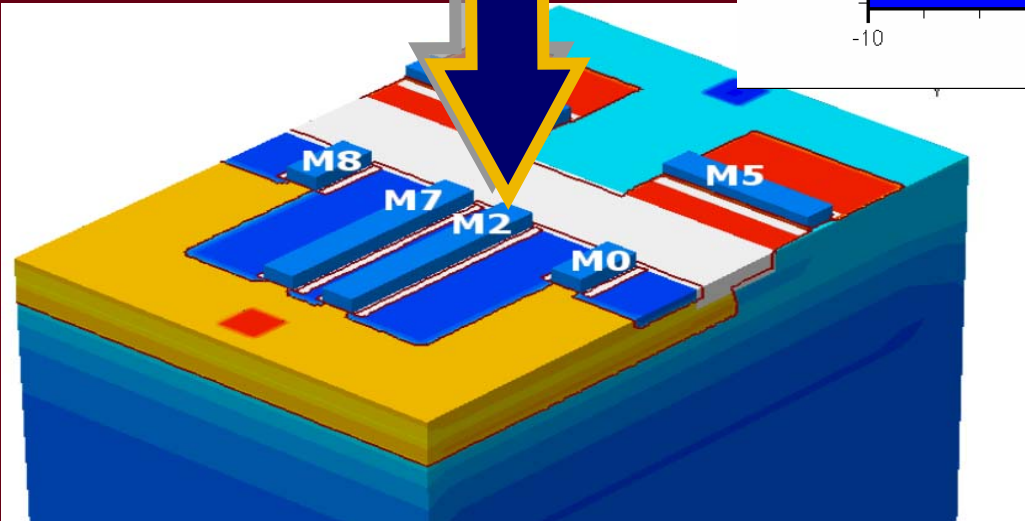
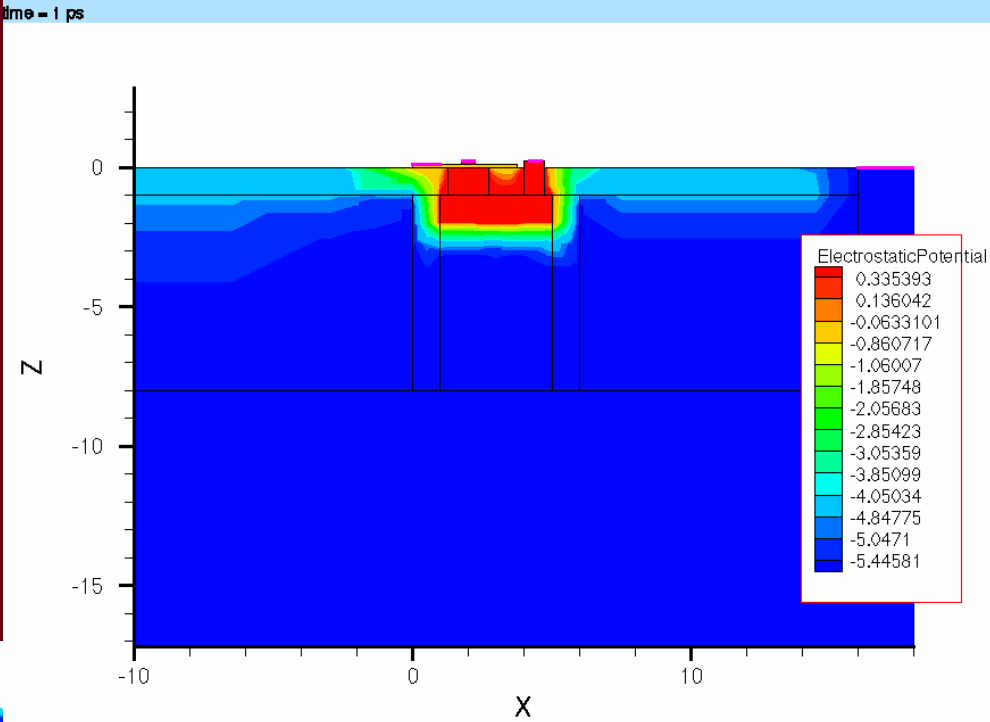
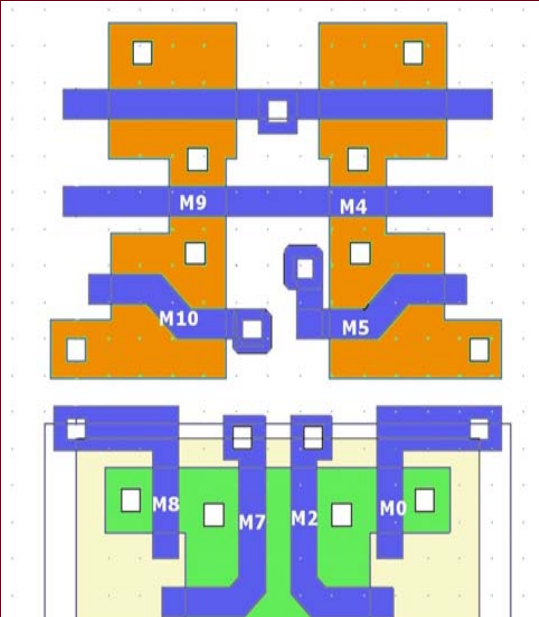

TCAD simulation of radiation event

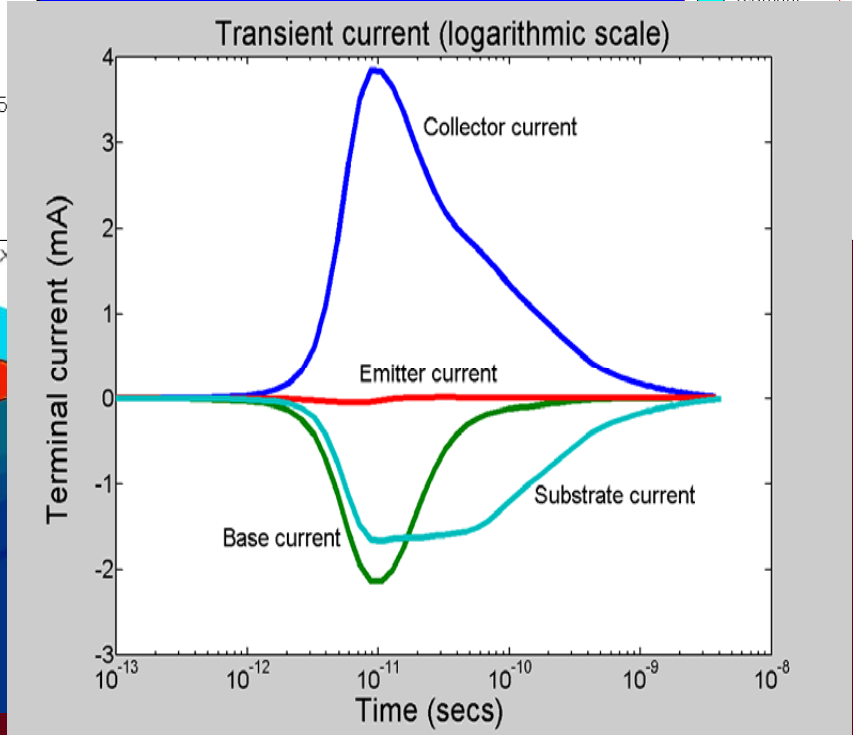
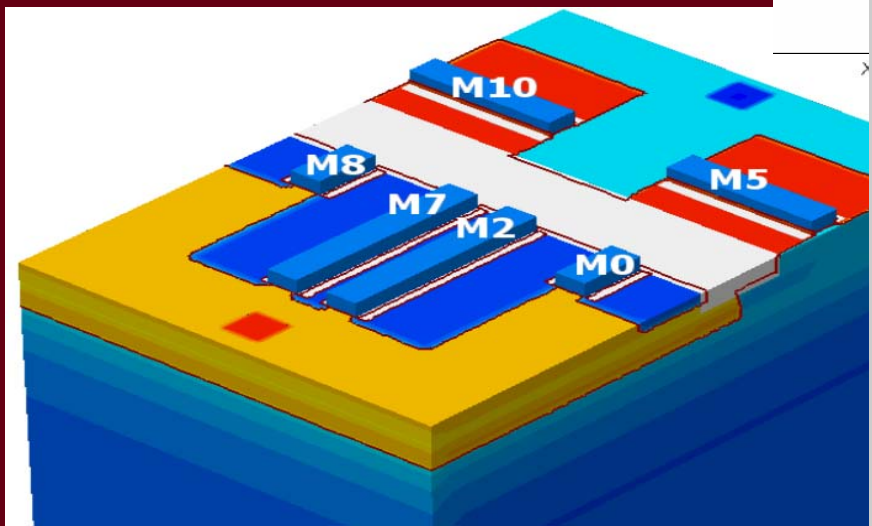
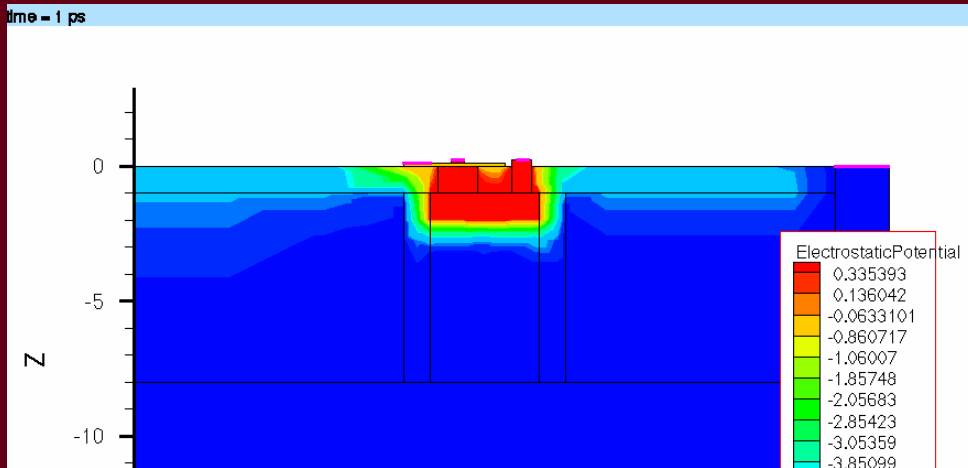
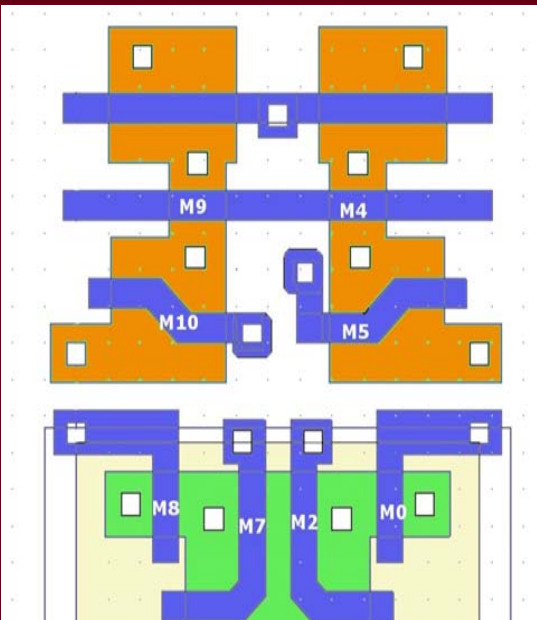

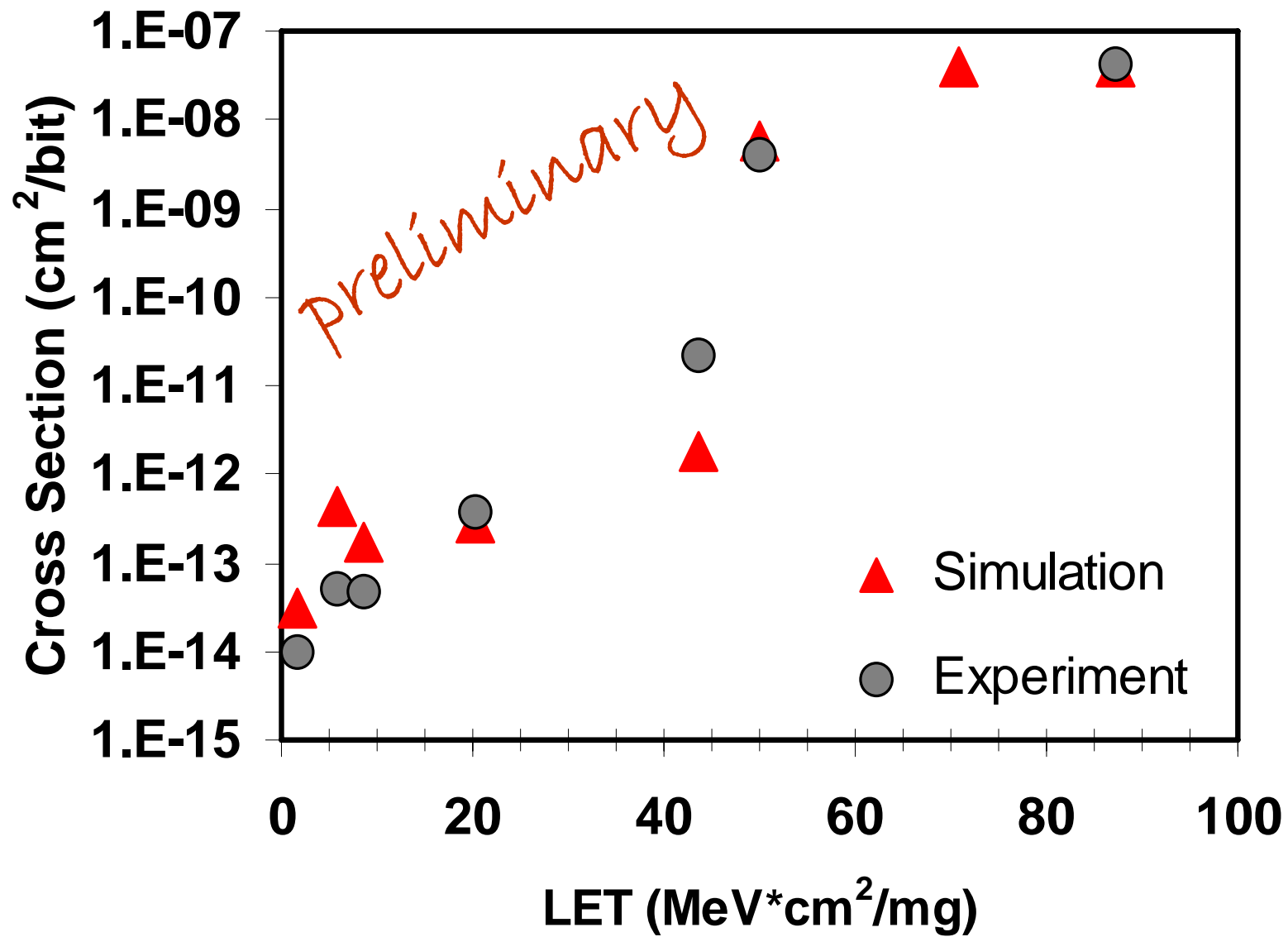

RADSAFE on SEE in SRAMs

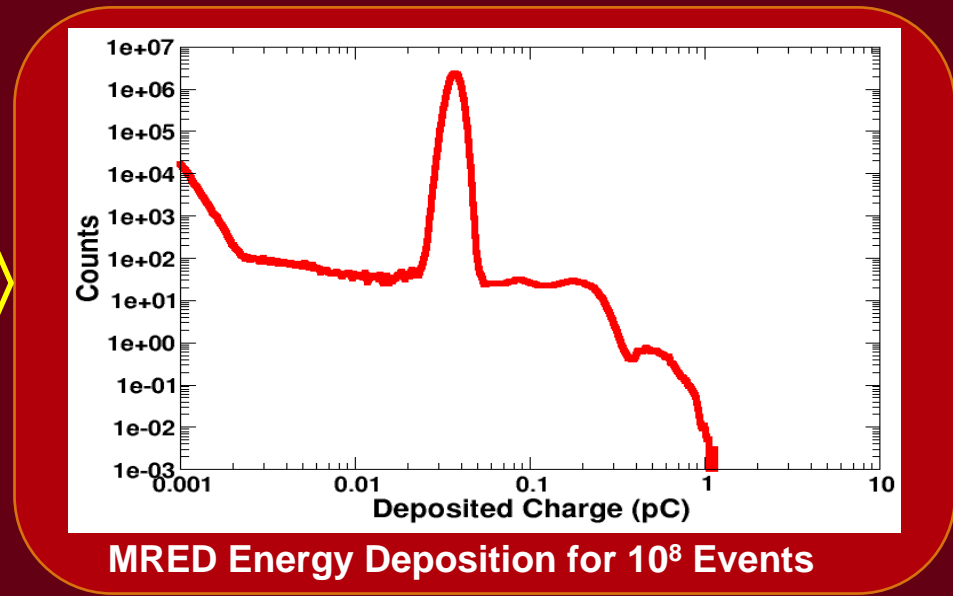
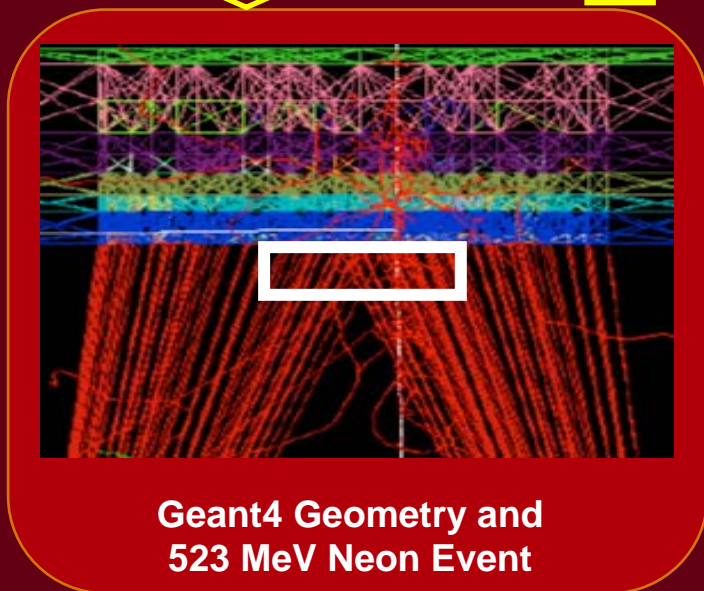
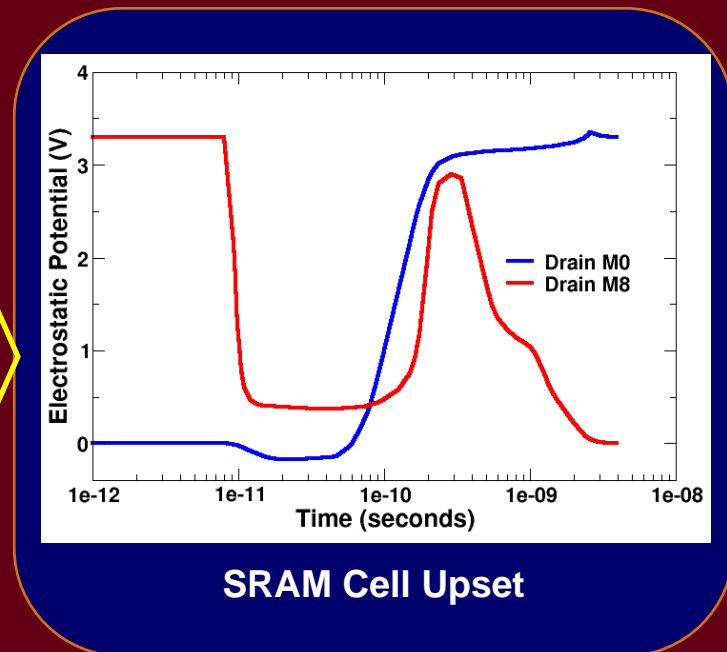
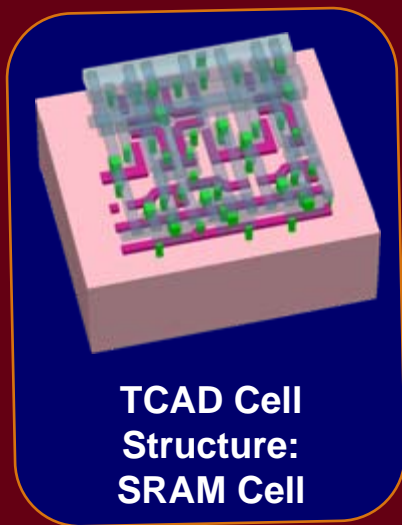

Summary

- We tried to overview Geant4 applications in NASA missions in particular for
 - Apparatus simulation
 - Planetary scale simulation
 - Micro-dosimetry simulation
- In this presentation, because of the time constraints, we missed many other excellent applications in above-mentioned areas and also many other application areas, for example
 - Spacecraft charging
 - Radiation shielding of spacecraft
- Comprehensive coverage of physics models and powerful geometrical modeling capability provided by Geant4 are quite suitable for mission-critical simulations.